

FAR TOOLS®



EP 1050B

Professional Machine

© FAR GROUP EUROPE

- FR Palan électrique (Notice originale)
- EN Electric hoist (Original manual translation)
- DE Elektroflaschenzug (Übersetzung aus dem Original-Anleitung)
- ES Aparejo eléctrico (Traducción del manual de instrucciones originale)
- IT Paranco elettrico (Traduzione dell'avvertenza originale)
- PT Cadernal eléctrico (Tradução do livro de instruções original)
- NL Elektrische takel (Vertaling van de originele instructies)
- EL ΗΛΕΚΤΡΙΚΟ ΠΑΛΓΚΟ (Μετάφραση από τις πρωτότυπες οδηγίες)
- PL Wciagarka elektryczna (Tłumaczenie z oryginalnej instrukcji)
- FI Sähkönosturi (Käännös alkuperäisestä ohjeet)
- SV Elektrisk lyftkran (Översättning från originalinstruktioner)
- BU Электрическа ЕДeбaтop (Превод на оригиналната инструкция)
- DA Elektrisk talje (Oversættelse fra oprindelige brugsanvisning)
- RO Mașină de ridicat electrică (Traducere din instrucțiunile originale)
- RU Электрическая таль (Перевод с оригинальной инструкции)
- TU Elektrikli palanga (Orijinal talimatlar çeviri)
- CS Elektrický kladkostroj (Překlad z originálního návodu)
- SK Elektrický kladkostroj (Preklad z originálneho návodu)
- HE תרגום מהראות מקוריית) מנוף הרמה חשמלי בקמ שיטפ)
- AR (قيلحصالآ تاميلعتلا زم قمجرتلا) قيلأبركة ةعفسار
- HU Elektromos emelőcsiga (Fordítás az eredeti utasítások)
- SL Električni vitel (Prevod iz izvornih navodil)
- ET Elektripool (Tõlge originaal juhiseid)
- LV Elektrinis keltuvas (Tulkojumā no instrukcijas oriģinālvalodā)
- LT Elektriskasis celtinis (Vertimas iš originalių instrukcijas)
- HR Električna dizalica (Prijevod prema originalne upute)



182007-3-Manual-G-2022.1024



fartools.com



10 min

MERCI !



En choisissant ce palan électrique **FARTOOLS**, vous permettez d'en diminuer l'impact environnemental !

Le retrait du calage en polystyrène et le remplacement par du carton permet une réduction de **70 %** du volume de son packaging.

De plus, en retravaillant l'emballage, nous avons supprimé **70 %** des produits dérivés des hydrocarbures.

Ces opérations ont ainsi permis d'abaisser ses émissions de gaz à effet de serre :

- il utilise moins de ressources naturelles,
- son volume transporté est nettement plus faible.

>>> Pour en savoir plus, flashez ce code et retrouvez toutes les informations sur notre site :





Description et repérage des organes de la machine
Description and location of machine parts

A

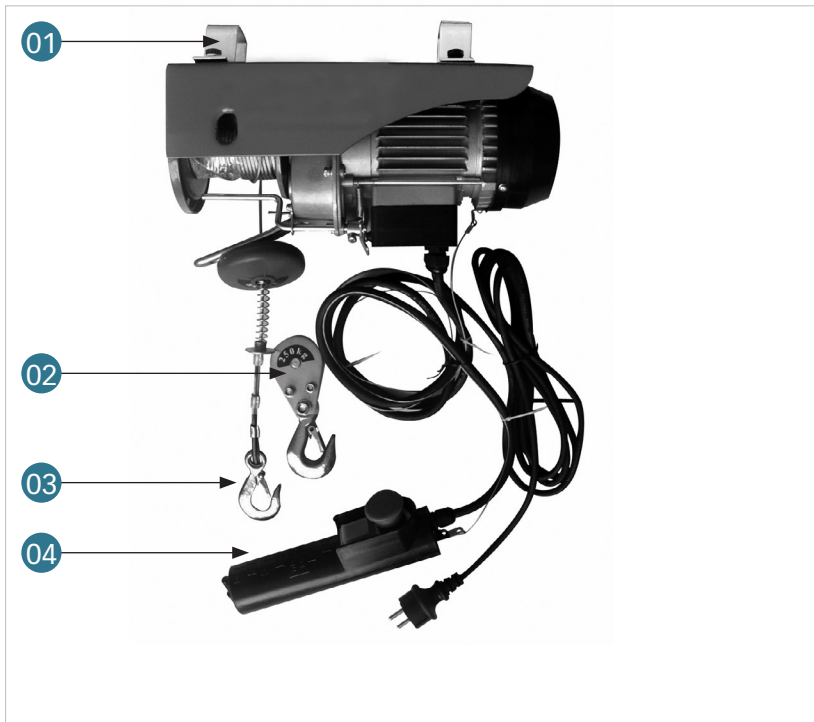

Contenu du carton
Contents of box

C



Points de collecte sur www.quotidienmarchés.fr
Privilégiez la réparation ou le don de votre appareil !

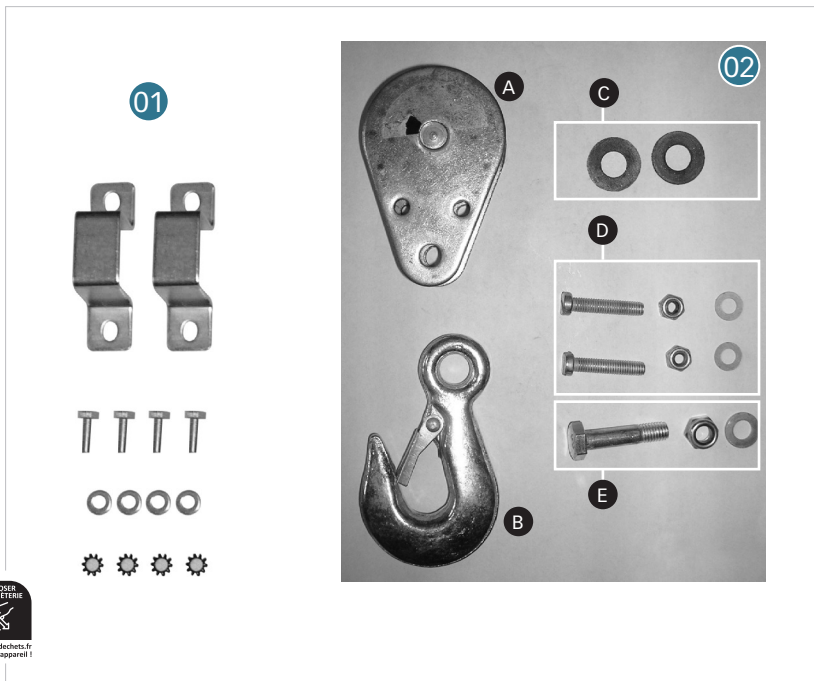



Assemblage de la machine
Assembling the machine

D

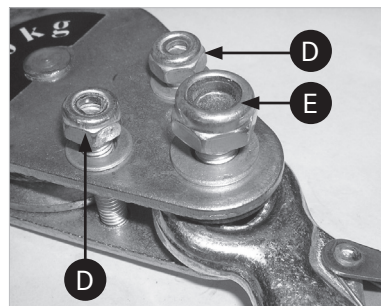
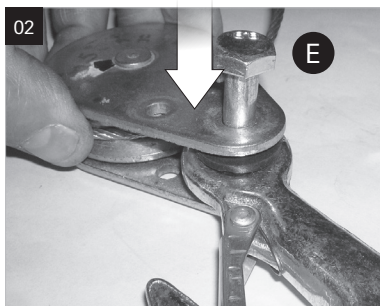
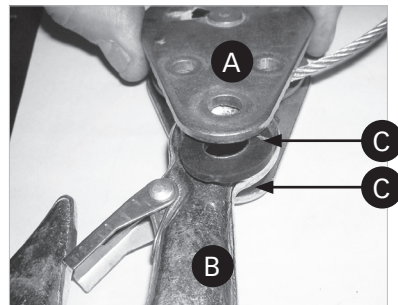
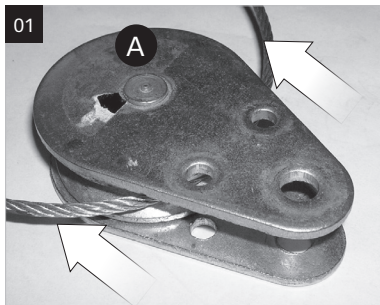

Ecrous frein NYLSTOP (2xM6 / 1xM8) - à remplacer lors de chaque montage
Noten rem NYLSTOP (2xM6 / 1xM8) - vervangen bij elke vergadering
Nueces del freno NYLSTOP (2xM6 / 1xM8) - reemplazar en cada asamblea
Porcas de freno NYLSTOP (2xM6 / 1xM8) - substituir em cada conjunto
Dadi freno NYLSTOP (2xM6 / 1xM8) - sostituire ad ogni gruppo
Nueces del freno NYLSTOP (2xM6 / 1xM8) - reemplazar en cada asamblea



D M6
E M8





01

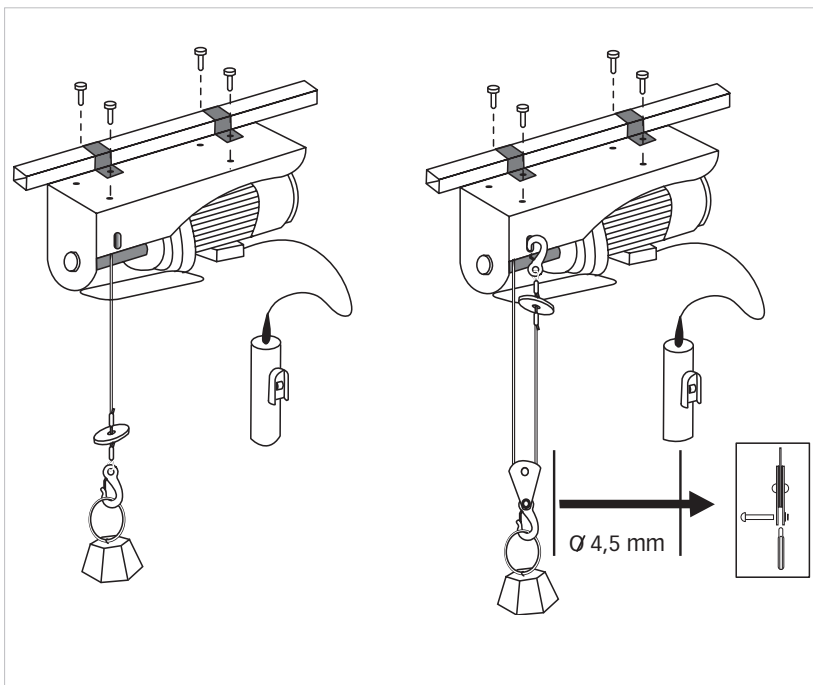

Fonctionnalité de la machine
Functions of the machine

E

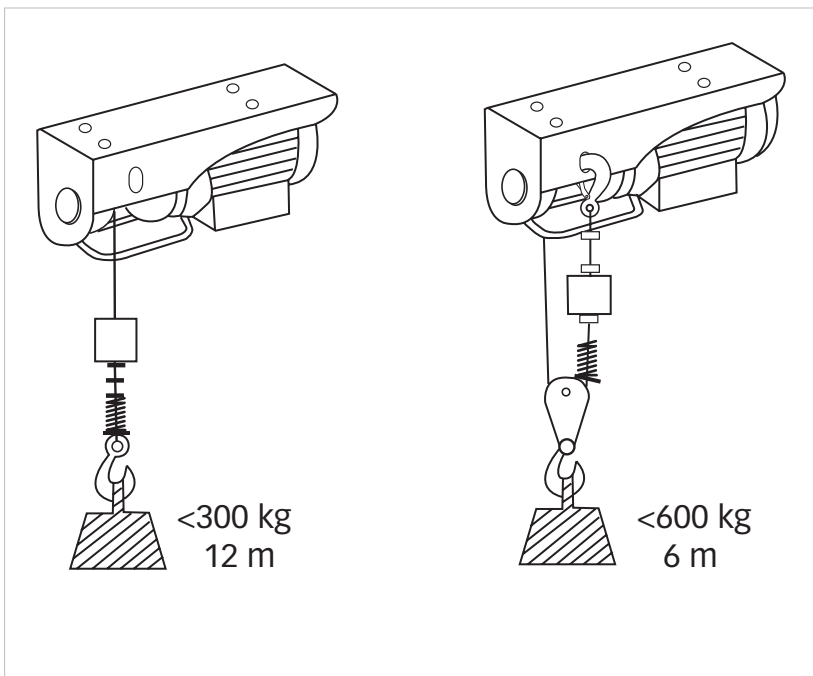



Fonctionnalité de la machine
Functions of the machine

E

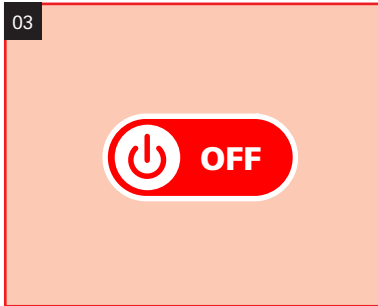
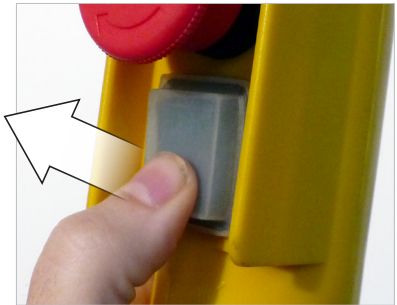
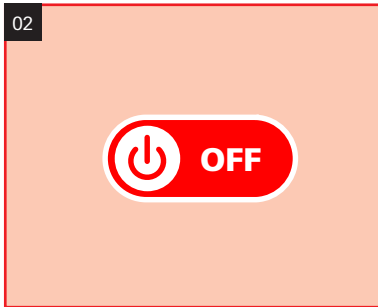
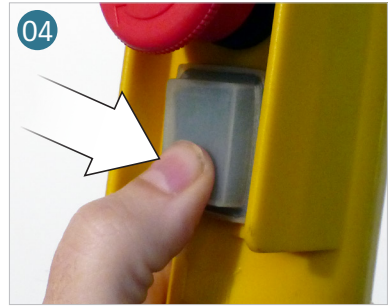
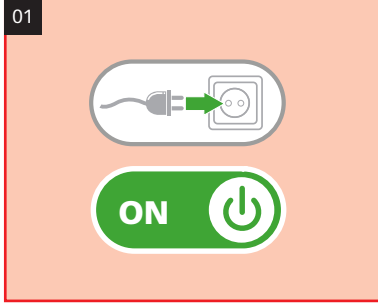

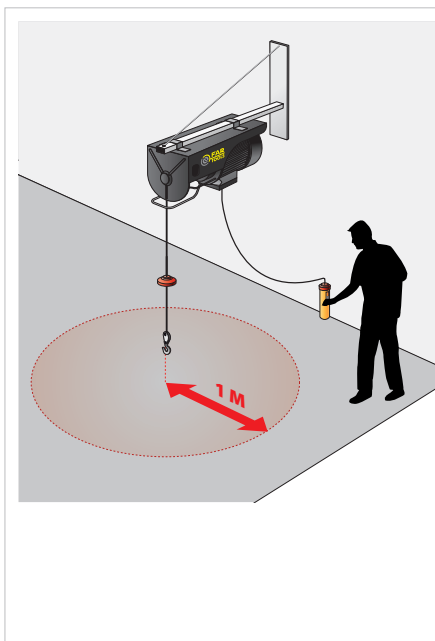

Respecter un rayon d'un mètre autour de la charge transportée

- Let op een straal van een tape rond de vervoerde lading
- Halten Sie einen Radius von einem Meter um die transportierte Last ein
- Respecter un radio de 1 metro alrededor de la carga transportada
- Respeitar um raio de 1 metro a volta da carga transportada
- Rispetta un raggio di un metro intorno alla carica trasportata
- Respect one meter radius around the transported load
- Respektujte poloměr jednoho metru kolem přepravovaného nákladu
- Dodržiavajte polomer jedného metra okolo prepravovaného nákladu
- Poštujte polumjer od jednog metra oko prevođenog tereta

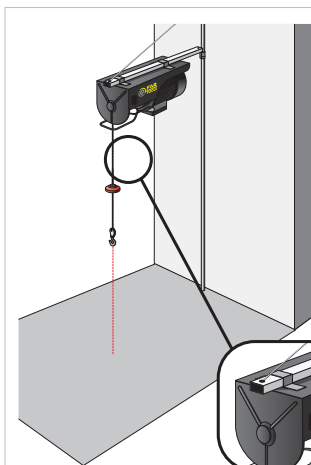

Ø 67,5 x 67,5 mm
Ep 4,5 mm MINI

• La fixation du palan sur votre support doit faire l'objet d'une étude de structure !

• Die Befestigung des Hebezeugs an Ihrer Stütze muss erfolgen das Thema einer strukturstudie!

• Bevestigen van de takel op uw steun moet een studie van de structuur!

• La fijación del polipasto en el brazo debe ser objeto de un estudio de la estructura!

• A fixação do guincho no suporte deve ser feita com um estudo da estrutura!

• La fissazione del paranco sul supporto deve essere oggetto di uno studio di struttura!

• Attaching the hoist on your support needs to be a study of structure!

• Připevnění zvedáku na vaši podporu musí provést předmět strukturální studie!

• Upevnenie zdviháka na vašu podporu musí byť predmet štruktúrálnej štúdie!

• Pričvrščivanje dizalice na vašem nosaču mora se izvršiti predmet strukturalne studije!

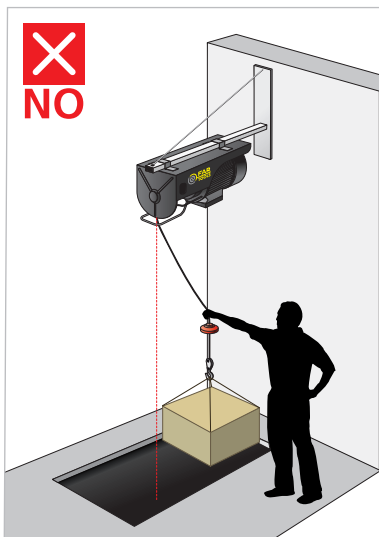

Si la charge doit être désaxée, le support du palan devra être mobile.

Wenn die Last versetzt werden muss, muss die Hubstütze beweglich sein.

Als de belasting moet worden scheef, ter ondersteuning van de hefwerktuig moet mobiel zijn.

Si la carga debe ser desviada, el brazo del polipasto debe ser móvil.

Se a carga deve estar fora do alinhamento, o suporte do guincho deve ser móbil.

Se la carica non è nell'asse, il supporto dovrà essere mobile.

If the load must be skewed, the support of the hoist must be moveable.

Pokud musí být náklad vyrovnán, musí být podpora zvedáku pohyblivá.

Ak musí byť záťaž vyrovnaná, musí byť podpora zdvíhaka pohyblivá.

Ako se opterečenje mora pomaknuti, nosač nosača mora biti mobilan.



Option - Option - Option - Opcional - Opzione - Opção - Opție - Επιλογή - Opcja - Valinnainen - Tillval -
 Дополнительно - Ekstra udstyr - Opzioni - Опция - seçenek / seçim - Volba - Vofba - הציפה - رای-ت-خ
 - Opció - Možnost - Valk - Opcija - Izvēle

REF : 182003



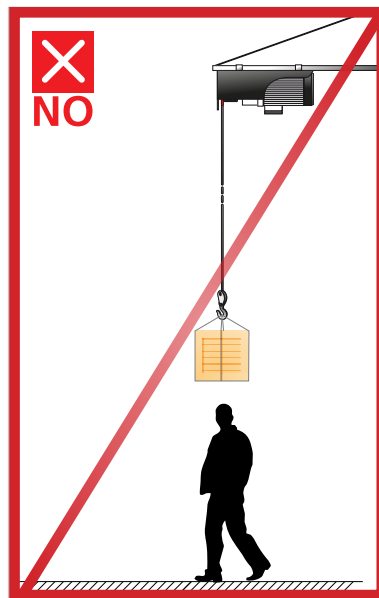
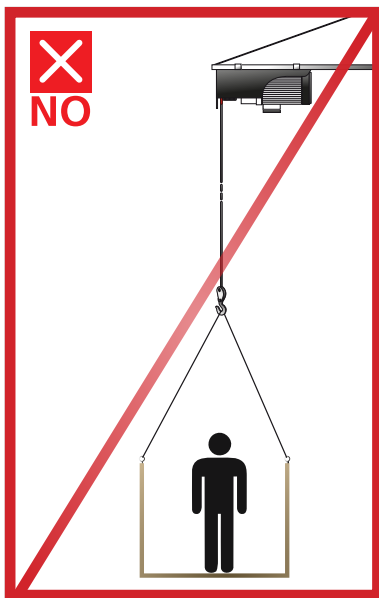
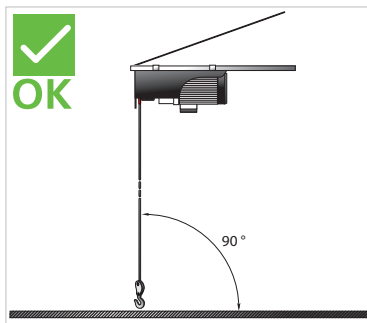
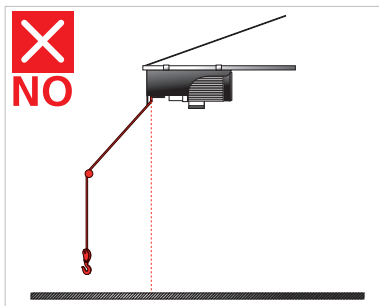



Entretien, recommandations et conseils.
Maintenance, recommendations and advice.

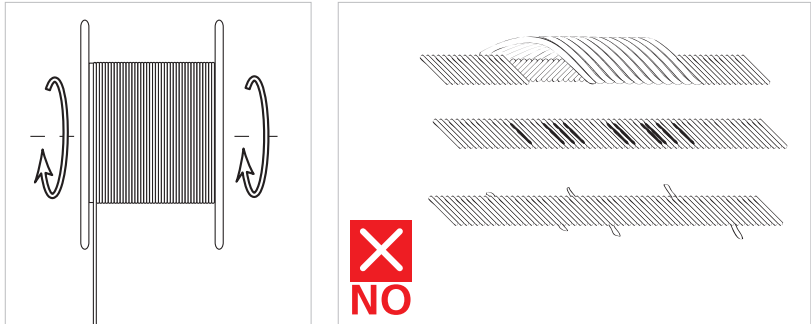
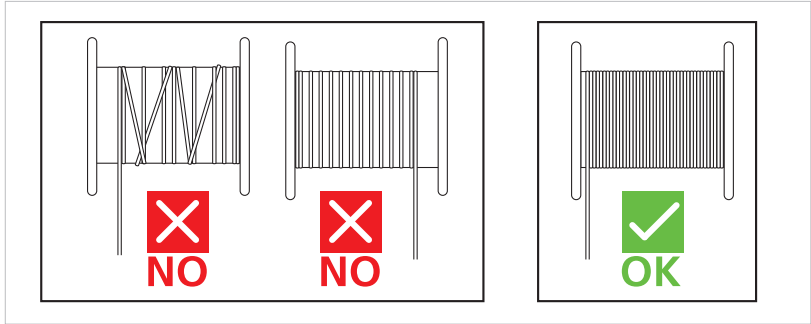





	<p>Tension et fréquence assignée : Nominal frequency and power: Spannung und Frequenz: Tensión y frecuencia fijada: Tensione e frequenza assegnata: Tensão e frequência fixa: Angewezene spanning en frequentie: Ονομαστική τάση και συχνότητα: Napięcie i częstotliwość przydzielona: Jännite ja määrätty taajuus: Angiven spänning och frekvens: Anført spænding og frekvens: Tensiune și frecvență de lucru:</p>	<p>Заданное напряжение и частота: Tahsis gerilimi ve frekans: Stanovené napätí a frekvence: Stanovené napätie a frekvencia: מחמת ותדר מוקצב. الغلطية والذبذبة الجبرمجة. Névleges feszültség és frekvencia: Napetost in določena frekvenca: Консумирано напрежение и честота : Määratud pinge ja sagedus Nustatyta įtampa ir dažnis Noteiktais spriegums un frekvence. Napon i nazivna frekvencija:</p>	230 V ~ 50 Hz
	<p>Puissance assignée : Nominal power: Leerlaufdrehzahl: Potencia fijada: Potenza assegnata: Potência assinada: Onbelast toerental: Ονομαστική ισχύς: Prędkość na biegu jałowym: Teho: Angiven effekt: Anført styrke: Putere de lucru:</p>	<p>Заданная мощность: Tahsis edilen güç: Stanovený výkon: Predpísaný výkon: כוח מוקצב. القدرة الجبرمجة. Névleges teljesítmény : Določena jakost: Консумирана мощност: Määratud võimsus. Nustatyta galia Noteiktā jauda Nazivna snaga:</p>	

	<p>Puissance assignée : Nominal power: Leerlaufdrehzahl: Potencia fijada: Potenza assegnata: Potência assinada: Onbelast toerental: Ονομαστική ισχύς: Prędkość na biegu jałowym: Teho: Angiven effekt: Anført styrke: Putere de lucru:</p>	<p>Заданная мощность: Tahsis edilen güç: Stanovený výkon: Predpísaný výkon: כוח מוקצב. القدرة الجبرمجة. Névleges teljesítmény : Določena jakost: Консумирана мощност: Määratud võimsus. Nustatyta galia Noteiktā jauda Nazivna snaga:</p>	1050 W - ED 20 % 150 s/h
	<p>Vitesse à vide: No-load speed: Drehzahl unbelastet: Velocidad vacía: Velocità a vuoto: Velocidade no vácuo: Leerlaufdrehzahl: Ηλεκτρικό ανυψωτικό Prędkość bezciążenia: Tyhjäkäyntinopeus Tomgångshastighet: Hastighed i ubelastet tilstand: Viteza în gol:</p>	<p>Скорость вращения на холостом ходу: Boşalma hızı: Rychlost naprázdno: Rýchlosť pri chode naprázdno: מהירות ריק. السرعة على الفراغ. Üres sebesség: Prosti tek: Скорост на празни обороти: Kiirus tühikäigul Tuščio prietaiso greitis Tukšgaitas ātrums Brzina praznog hoda:</p>	

	<p>Vitesse à vide: No-load speed: Drehzahl unbelastet: Velocidad vacía: Velocità a vuoto: Velocidade no vácuo: Leerlaufdrehzahl: Ηλεκτρικό ανυψωτικό Prędkość bezciążenia: Tyhjäkäyntinopeus Tomgångshastighet: Hastighed i ubelastet tilstand: Viteza în gol:</p>	<p>Скорость вращения на холостом ходу: Boşalma hızı: Rychlost naprázdno: Rýchlosť pri chode naprázdno: מהירות ריק. السرعة على الفراغ. Üres sebesség: Prosti tek: Скорост на празни обороти: Kiirus tühikäigul Tuščio prietaiso greitis Tukšgaitas ātrums Brzina praznog hoda:</p>	8m/min - 4 m/min
	<p>Copyright © - 2023 - Fargroup. All rights reserved.</p>	<p>Plus d'info sur fartools.com</p>	



	<p>Porter des lunettes de sécurité : Wear protective eyewear : Schutzbrille tragen : Llevar puestas gafas protectoras : Portare de gli occhiali di sicurezza : Utilizar óculos de segurança : Draag een veiligheidsbril : Φοράτε γυαλιά ασφαλείας: Zakładać okulary ochronne : Käytä suojalaseja : Använd skyddsglasögon : Der skal benyttes sikkerhedsbriller : Purtati ochelari de protectie :</p>	<p>Наденьте защитные очки : Güvenlik gözlükleri takın : Používejte bezpečnostní brýle : Noste ochranné okuliare : תחשיב יקשם ביכרהל אנ חגל נזפארט וקאי. Viseljen védőszemüveget : Nositi zaščitna očala : Да се използват защитни очила : Kandke kaitseprille Nešioti apsauginius akinius Valkät aizsargbrilles Nositi zaštitne naočale:</p>	X
---	---	--	---

	<p>Porter un masque anti-poussière : Wear a dust mask : Staubschutzmaske tragen : Llevar puesta una careta de protección contra el polvo : Indossare una mascherina anti-polvere : Utilizar uma máscara anti-poeira : Draag een stofmasker : χρήση προστατευτική μάσκα : Zakładać maskę przeciwpyłową Käytä pölysuojust : Bär mask mot damm : Der skal benyttes beskyttelsesmaske mod støv: Purtati mască anti-praf :</p>	<p>Наденьте респиратор : Toza karşi maske takın : Používejte masku proti prachu : Noste ochrannú masku proti prachu : קבא דגנ הכסמ שובחל אנ ליס צנא עפראש ללעגאר. Viseljen porvédő maszkot Nositi zaščitno masko proti prahu: Да се използва защитна маска : Kandke tolmumaski. Dévėti respiratorių Valkät aizsarg masku pret putekļiem Nositi masku za zaštitu od prašine:</p>	X
---	--	---	---

	<p>Porter une protection auditive : Wear hearing protective equipment: Gehörschutz tragen: Llevar puesta una protección auditiva: Portare una protezione uditiva: Utilizar uma protecção auditiva: Draag gehoorbeschermers: Φοράτε προστασία ακοής: Zakładać słuchawki ochronne Käytä kuulosuojaimia: Bär hörselskydd: Der skal benyttes høreværn: Purtati căști de protecție auz:</p>	<p>наденьте средства звуковой защиты: İşitsel koruma aleti takın: Používejte ochranu sluchu: Noste ochranné slúchadlá: יש ל הרכיב הגנת שמיעה ליס חוזה פרש הצרעי Viseljen fülvédőt Nositi zašito ušes: Да се използва слухови защитни средства: Kandke kõrvakaitset Nešioti apsauga nuo triukšmo Valkät dzirdes aizsarglīdzekli Nositi šitņike protiv buke:</p>	X
--	---	--	---

	<p>Porter des gants : Use rubber gloves : Schutzhandschuhe tragen : Llevar guantes de protección : Indossare i guanti di protezione : Utilizar luvas de protecção : Draag veiligheidshandschoenen : χρήση προστατευτικών γαντιών : Używać rękawic ochronnych : Käytä suojakäsineitä : Använd skyddshandskar : Der skal benyttes handsker : Purtati mănuși :</p>	<p>Наденьте перчатки : Eldiven takın : Noste rukavice : Noste rukavice : תופכ שובלל אנ ליס ופארזאט. Viseljen kesztyű t Nositi rokavice: а се използват предпазни ръкавици : Kandke kindaid Mūvēti pirštines Valkät cimdus Nositi zaštitne rukavice:</p>	X
---	--	---	---





	<p>Lire les instructions avant usage : Read the instructions before use : Vor Einsatz des Geräts Anweisung lesen : Léase las instrucciones antes de usar : Leggere le istruzioni prima dell'uso : Ler as instruções antes da utilização : Lees voor het gebruik de instructies : Διαβάστε τις οδηγίες πριν από τη χρήση: Zapoznać się z instrukcją przed użyciem : Lue ohjeet ennen käyttöä : Läs anvisningarna före användning : læs instruktionerne før brug Înainte de utilizare, citiți instrucțiunile :</p>	<p>Внимательно прочитайте следующие инструкции : Kullanmadan talimatları okuyunuz : Pozorně si přečtete následující pokyny : Pred použitím si precitajte pokyny : זרם חילופי اقرأ التعليمات قبل الاستخدام. használat előtt olvassuk el az utasítást : Pred uporabo preberite ustrezna navodila : Прочетете указанията за употреба : Enne kasutamist lugege instruksiooni Prieš naudojimą perskaityti instrukciją izlasīt instrukcijas pirms lietošanas Pročitati upute prije uporabe:</p>	X
--	---	---	---

	<p>Conformité européenne : Conforms to EC standards : CE-Konformität : Cumples con las directivas CE : Conforme alle norme CE : Conforme às normas CE : Voldoet aan de EG-normen : Ευρωπαϊκή Συμμόρφωση: Zgodność z normami CE : EU-standardien mukainen : Overholder EU standarderne : Conform cu normele europene:</p>	<p>соответствие европейским стандартам: Avrupa uygunluk : Evropská shoda : Európska dohoda : התאמה לתקנים האירופיים مطابقت للمواصفات الأوروبية. Evropska ustreznost : Európai megfeleléség : Съответствие с европейските норми : Euroopa Liidu vastavusmärk Europinių normų atitikima Atbilstība Eiropas standartiem Europska sukladnost</p>	X
--	--	--	---

	<p>Danger : Danger : Gefahr : Peligro : Pericolo : Perigo : Gevaar : Κίνδυνος: Niebezpieczeństwo : Vaara : Fara : Fare : Pericol :</p>	<p>Опасно : Tehlike : Nebezpečí : Nebezpečnost : סכנה. خطر. Veszély : Nevarnost: Опасност : Oht Pavojus Bistamība Opasnost:</p>	X
--	---	---	---

	<p>Poids : Weight : Gewicht : Peso : Peso : Peso : Gewicht : Βάρος : Masa : Paino : Vikt : Vægt : Greutate :</p>	<p>Вес : Ağirlik : Hmotnost : Hmotnost : משקל الوزن. Súly : Teža : Terlo : Raskus Svoris Svars Težina:</p>	18,00 kg
--	---	--	----------



 LWA	Niveau de puissance acoustique :	уровень мощности звука :	80 dB (A)
	Acoustic power level :	Акустик басың seviyesi :	
	Schalleistungspegel :	Hladina zvukového výkonu:	
	Nível de potencia acústica :	Hladina zvukového výkonu:	
	Livello di potenza acustica:	רמת כוח אקוסטי.	
	Nível de potência acústica:	مستوى الخرجي ج.	
	Niveau akoestisch vermogen :	a hangnyomás szintje :	
	Επίπεδο ισχύος ήχου:	Nivo akustične jakosti :	
	Poziom mocy akustycznej :	Равнище на вибрации :	
	Käytä suojalaseja :	Helivõimsuse nivoo	
	Ljudstyrkenivå :	Triukšmo lygis	
	Lydstyrke :	Akustiskās jaudas līmenis	
	Nível putere acustică :	Razina zvučne snage:	

NIVEAU SONORE D'ÉMISSION :

A VIDE

Puissance acoustique LWA

80 dB

Incertitude

3

Valeurs déterminées suivant le code d'essai de l'annexe B de la norme EN 61029-1 avec emploi des normes de base ISO 11201 et ISO 3744.

Les niveaux de pression acoustique obtenus in situ dépendent :

- Des niveaux réels de la machine considérées, en prenant en compte les incertitudes déclarées;
 - Du local et de l'installation de la machine. Préférez une pièce dont l'acoustique est plus feutrée.
- Évitez les pièces vide à grande résonance. Placez vous auprès d'une fenêtre le cas échéant.
- Des outils montés, des pièces travaillées, des réglages choisis,...



		12-6 m
		300 - 600 kg
		4,5 mm

	<p>Soumis à recyclage Subjected to recycling Sujeto a reciclaje Sottoposti a riciclaggio Sujeitos à reciclagem Não deite no lixo Niet wegwerpen Υπόκειται σε ανακύκλωση Nie wyrzucac Älä heittää pois luontoon Batteriet får inte kastas Bortkast det ikke Nu le auncati</p>	<p>Подлежит переработке Atmayınız Nevyhazujte je do běžného odpadu Neodhadzovat Gjenvinningspliktig فلا ترمدها لهذا في القمامة. ne mečíte! Ne odvržite ga/jih vstran Taaskasutusse kuuluv Ärge visake seda minema Nemétykíte Nemest Podvrgnuto recikliranju</p>	X
--	--	---	---

Recyclage des déchets :

Les outils, accessoires et leur emballages doivent suivre une voie de recyclage adaptée. Conformément aux directives Européenne 2012/19/UE et 2006/66/CE, les composants d'un produit doivent être séparés, collectés, recyclés ou éliminés en conformité avec les réglementations environnementales en vigueur. Les appareils, batteries, piles, huiles, emballages devront être déposés dans les systèmes d'élimination des déchets spéciaux tels que déchetteries. Renseignez-vous auprès de votre commune pour connaître l'organisme le plus proche à même de traiter ou de collecter ces déchets.

	<p>Recyclable, soumis au tri sélectif Recyclable, subject to recycling Recyclingfähige, unterliegen Recycling Reciclables, sujetos a reciclaje Riciclabili, soggetti a riciclaggio Recicláveis, sujeito à reciclagem Recycleerbare, onderworpen aan recycling Ανακυκλώσιμο, υπόκειται σε επιλεκτική διαλογή Opakowanie nadaje się do recyklingu podlegają recyklingu Kierrätettävien pakkausten kohteena kierrätys Återvinningsbara förpackningar omfattas återvinning Рециклиращи се опаковки подлежат на рециклиране Genanvendelig underlagt genbrug</p>	<p>Reciclabile sub rezerva reciclare Повторно упаковка подлежит вторичной переработке Geri dönüştürülebilir ambalaj konusu Recyklovateľné podléhajúci recyklácii Recyklovateľné podliehajúce recyklácii Resirkulerbar, med forbehold om selektiv sortering ريديتلا دا بال يضرمت ريديتلا دا بال قاباؤلا فصول غنلاو توبعتلا Újrahasznosítható csomagolás alá újrahasznosítás Reciklirati predmet recikliranje Pakendite suhtes ringlussevõtu Pärstrådajams iepakojums otrreizējai pārstrādei Perdirbamy taikomos perdirbimo Može se reciklirati, podložno selektivnom sortiranju</p>	X
--	--	--	---





EP 1050B

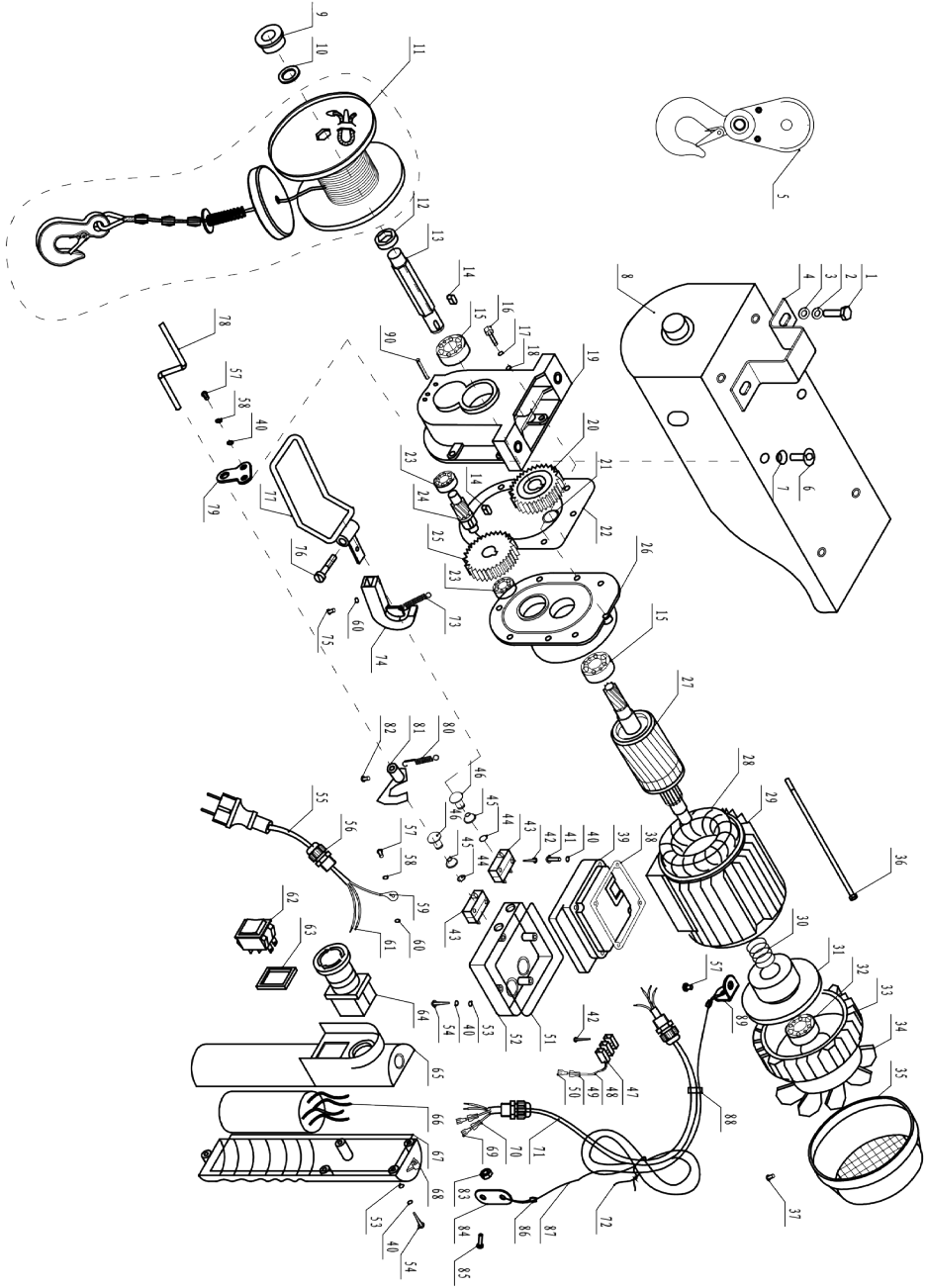



DECLARATION DE CONFORMITE
 VERKLARING VAN OVEREENSTEMMING
 DECLARACION DE CONFORMIDAD
 DICHIARAZIONE DI CONFORMITA
 KONFORMITÄSERKLÄRUNG
 DECLARATION CONFORMITY
 DECLARAÇÃO DE CONFORMIDADE
 DEKLARACJA ZGODNOSCI Z NORMAMI
 OM ÖVERENSSTÄMMELSE
 VAATIMUSTENMUKAISUUSVAKUUTUS
 ÖVERENSSTEMMELSESERKLÆRING
 ΔΗΛΩΣΗ ΣΥΜΜΟΡΦΩΣΗΣ

DECLARAȚIE DE CONFORMITATE
 VYHLÁSENIE ZHODY
 Декларация соответствия
 הצהרת תואמת
 التصديق بالمطابقة
 PROHLÁŠENÍ SHODY
 EGYZESÉGI NYILATKOZAT
 Декларация за съответствие с нормите
 IZJAVA O SKLADNOSTI
 DEKLARACIJA
 ATITIKTIES DEKLARACIJA
 KINNITUS
 IZJAVA O SUKLADNOSTI

Le soussigné,
 Ondergetekende,
 Der Unterzeichner,
 O abaixo assinado,
 Undertecknad,
 Долуподписаният
 Undertegnede
 Subseminatul,
 Я, нижеподписавшийся,
 Imzalanay,
 Niže podepsány,
 Toliau pasirašęs

Personne autorisée à constituer
 le dossier technique :
 Christophe HURE



FAR GROUP EUROPE
 192, Avenue Yves Farge
 37700 St. Pierre-des-Corps
 FRANCE

El suscrito,
 Il sottoscritto,
 The undersigned,
 Nínej podpísany
 Allékirjoittanut,
 Ο κάτωθι υπογεγραμμένος,
 Nizšie podpísany
 החתום מתה
 الحقوقي أدناه
 Alulírott,
 Podpisani,
 Apakšā parakstījis
 allakirjutanu
 Dolje potpisani,

Declara por la presente, que,
 Dichiare che,
 Declares that,
 Oowiadcza niniejszym, że
 Ilmoitetaan täten että,
 Δια του παρόντος δηλώνει ότι,
 tымто выхласује, że
 מצהיר בה כן
 يصرح استنادا على ذلك
 kijelentem, hogy a készülék Izjavlja da,
 Pareiškia, kad,
 Ar šo apliecinā, ka,
 Kinnitab, et
 izjavljuje u ovom dokumentu da je

Déclare par la présente que,
 Verklaart hiermede dat,
 Erklärt hiermit daß,
 Declara pela presente que,
 Förklarar härmed att
 Заявлява с настоящото
 erklærer hermed, at
 Declar prin prezenta că,
 настоящим подтверждаю, что
 Mecvut belgeyle beyan edilyor ki,
 tímto prohlašuje, že,
 Pareiškia, kad,

code

FARTOOLS / 182007 / EP 1050B / YT-300/600-AW

Est conforme et satisfait aux directives et normes CE,
 In overeenstemming is met en Voldoet aan EG richtlijnen,
 Den folgenden EU-Bestimmungen entspricht,
 Respeita e está em conformidade com as normas CE,
 Överensstämmer med och uppfyller EG-standarder,
 Съответства и отговаря европейските норми
 Er i overensstemmelse med og overholder EU standarderne
 Este conform și satisface normele CE
 полностью соответствует и удовлетворяет
 требованиям стандартов ЕС
 CE şartlara uygundur,
 odpovídá normám ES.
 Atitinka ir atitinka EB direktyvas ir standartus,

Cumple con la directivas de la CE,
 E conforme alle direttive CEE,
 Complies with the EEC directives and standards,
 Odpowiada normom UE,
 Täyttää EU-vaatimukset,
 Συμμορφώνεται και ικανοποιεί τις οδηγίες και τα πρότυπα CE,
 zodpovedá normám ES.
 מתאים ועונה לתקני
 CE
 بأن الجهاز يطابق و يلبى معايير مجموعة الدول الأوروبية
 kielégíti a CE szabványok előírásait.
 Je v skladu z in izpolnjuje norme Evropske skupnosti.
 Atbilst un atbilst EK direktivas un standartus,
 Vastab ja vastab EU direktiividele ja standarditele,
 Sukladan i ispunjava direktive i standarde CE,

2006/42/EC 2014/30/EU 2011/65/EU&2015/863/EU

EN 55014-1:2017+A11
 EN 55014-2:2015
 EN IEC 61000-3-2:2019
 EN 61000-3-3:2013
 EN ISO 12100:2010
 EN 14492-2:2019
 EN 60204-32:2008

Christophe HUREL,
 Président Directeur Général
 06/12/2022
 Fait à St. Pierre-des-Corps



FAR TOOLS

EP 1050B
182007

230 V - 50 Hz 1050 W ED:20%
150 s/h

8 m/min - 4 m/min

300 / 600 kg

ø 4,5 mm

H = 12 m / 6 m

FAR GROUP EUROPE - 192, Avenue Yves farge - 37700 St. Pierre-des- Corps - FRANCE
YT-300/600-AW
Serial number / numéro série :

CE ⚠ ~~X~~ **IP 54**
Made in P.R.C.

182007-3-Sticker-D.indd 1

13/08/2020 16:07

GARANTIE - WARRANTY



FR. GARANTIE

Cet outil est garanti contractuellement contre tout vice de construction et de matière, à compter de la date de vente à l'utilisateur et sur simple présentation du ticket de caisse. La garantie consiste à remplacer les parties défectueuses. Cette garantie n'est pas applicable en cas d'exploitation non conforme aux normes de l'appareil, ni en cas de dommages causés par des interventions non autorisées ou par négligence de la part de l'acheteur. La garantie ne s'applique pas sur les dommages causés par une défaillance de l'outil.

DE. GARANTIE

Die Garantiezeit für dieses Gerät in bezug auf Konstruktions- und Materialfehler beträgt lt. Vertrag bei Vorlage des Kassenbons. Die Garantieleistung besteht im Ersatz schadhafter Teile. Die Garantie erlischt bei einem Einsatz des Geräts, der nicht normentsprechend ist, bei Schäden, die auf unsachgemäße Eingriffe zurückzuführen sind bzw. bei Nachlässigkeit seitens des Käufers. Die Garantie erstreckt sich nicht auf Schäden, die auf Fehlfunktionen des Geräts zurückzuführen sind.

IT. GARANZIA

Quest' attrezzo è garantito per contratto contro qualsiasi difetto di costruzione e di materia, a partire dalla data di vendita all'utente e su semplice presentazione dello scontrino. La garanzia consiste nel sostituire le parti difettose. Questa garanzia non è applicabile in caso di sfruttamento non conforme alle norme dell'apparecchio, né in caso di danni causati da interventi non autorizzati o da negligenza da parte dell'acquirente. La garanzia non si applica ai danni causati da un'avaria dell'attrezzo.

EN. GARANTIE

This tool is guaranteed, in writing, against any defect in manufacture or parts from the date of sale, upon simple presentation of the sales slip. The guarantee is limited to the replacement of faulty parts. This guarantee is not applicable in the event of usage which is not conform with the intended usage of the apparatus, nor in the event of damage caused by unauthorised servicing or negligence on behalf of the purchaser. This guarantee does not apply to any damage caused by the failure of this tool.

ES. GARANTIA

Esta herramienta se garantiza contractualmente contra todo defecto de construcción y materia, a partir de la fecha de venta a l' usuario y sobre simple pre-

sentación del recibo de caja. La garantía consiste en sustituir a las partes defectuosas. Esta garantía no es aplicable en caso de explotación no conforme a las normas del aparato, ni en caso de daños causados por intervenciones no autorizadas o por negligencia por parte del comprador. La garantía no se aplica sobre los daños causados por un fallo del herramienta.

NL. GARANTIE

Dit gereedschap heeft een garantie tegen constructiefouten en materiaaldefecten, die geldig is vanaf de aankoopdatum door de gebruiker, op vertoning van de kassabon. De garantie betreft de vervanging van de defecte onderdelen. Deze garantie is niet van toepassing indien het apparaat niet volgens de normen gebruikt is, noch in geval van schade veroorzaakt door oneigenlijk gebruik of nalatigheid van de koper. De garantie is niet van toepassing op schade voortvloeiend uit een defect van het gereedschap.

PT. GARANTIA

Esta ferramenta tem uma garantia contratual contra qualquer defeito de construção e de material, a partir da data de venda ao utilizador e sobre simples apresentação do talão da caixa. A garantia consiste em substituir as partes defeituosas. Esta garantia não é aplicável no caso de exploração não conforme às normas do aparelho, nem em caso de danos causados pelas intervenções não autorizadas ou por negligência da parte do comprador. A garantia não se aplica para os danos causados por uma falha da ferramenta.

EL. ΕΓΓΥΗΣΗ

Αυτό το εργαλείο είναι συμβατικά εγγυημένο έναντι τυχόν κατασκευαστικών και υλικών ελαττωμάτων, από την ημερομηνία πώλησης στον χρήστη και με την επίδειξη της απόδειξης πώλησης. Η εγγύηση περιλαμβάνει την αντικατάσταση των ελαττωματικών εξαρτημάτων. Αυτή η εγγύηση δεν ισχύει σε περίπτωση λειτουργίας που δεν συμμορφώνεται με τα πρότυπα της συσκευής, ούτε σε περίπτωση ζημιάς που προκαλείται από μη εξουσιοδοτημένες επεμβάσεις ή αμέλεια εκ μέρους του αγοραστή. Η εγγύηση δεν ισχύει για ζημιές που προκαλούνται από βλάβη του εργαλείου.

PL. GWARANCJA

Narzędzie jest objęte gwarancją na wszelkie wady konstrukcyjne i materiałowe, licząc od daty sprzedaży u użytkownika i po okazaniu paragonu kasowego. Gwarancja obejmuje wymianę cz.ści wybrakowanych. Gwarancja nie znajduje zastosowania w przypadku użycowania niezgodnego z normami urządzenia, ani w przypadku szkód spowodowanych działaniami niedozwolonymi lub niezabdaniami ze strony nabywcy. Gwarancja nie obejmuje szkód powstałych z powodu upadku urządzenia.

SV. GARANTI

Detta verktyg har en avtalsenlig garanti

mot konstruktions och materialfel, från och med tidpunkten för användarens inköp och genom uppvisning av kassakvittot. Garantin består i att ersätta de bristfälliga delarna. Denna garanti gäller inte om användningen inte motsvarar apparatens standarder, inte heller vid skador som orsakas av ej tillåtna ingrepp eller på grund av köparens vårdslöshet. Garantin gäller inte förskador som orsakats av att verktyget fungerat bristfälligt.

FI. TAKUU

Tämän laitteen takuu on voimassa sopimuksenmukaisesti kattaen kaikki rakenne- ja materiaali- ja lukien ostopäivästä kassakuitista vastaan. Takuu sisältää viallisten osien korvaamisen. Takuu ei korvaa ohjeidenvastaista käyttöä eikä valtuuttamattomien henkilöiden käsittelyä tai ostajan huolimattomuudesta aiheutuneita vahinkoja. Takuu ei vastaa myöskään toimintahäiriöistä aiheutuneita vahinkoja.

BU. Гаранция

Този инструмент е под договорна гаранция срещу всякакъв дефект в изработката и използваните материали, считано от датата на продажба на потребителя и само срещу представяне на касовата бележка. Гаранционното обслужване се състои в замяна на дефектните части. Настоящата гаранция не е валидна когато апаратът се използва по начин, несъответстващ на стандарта за работа с него, както и в случаи на щети, нанесени от неотторизирани лица, или вследствие на проявена небрежност от страна на потребителя.

Гаранцията не покрива щети, произтекли вследствие на техническа неизправност на апарата.

DA. GARANTI

Dette værktøj er dækket af en garantikontrakt for konstruktions- og materialefejl, som gælder fra købsdatoen ved visning af kassebonen. Garantien består i at udskifte de defekte dele. Garantien dækker ikke fejl opstået som følge af anvendelse, som ikke overholder standarderne for apparatet, eller skader opstået ved ikke autoriserede indgreb eller sløshed fra brugerens side. Garantien dækker ikke skader opstået, fordi værktøjet har svigtet.

RO. GARANTIE

Acest aparat este garantat din punct de vedere contractual împotriva tuturor viciilor de construcție și de material, începând de la data vânzării lui către utilizator și la simpla prezentare a bonului de casă. Garanția constă în înlocuirea componentelor defecte. Această garanție nu se aplică în cazul exploatarei în alt mod decât cel recomandat de normele aparatului și nici în caz de stricăciuni provocate de intervenții neautorizate sau prin aplicarea cumpărătorului. Garanția nu se aplică asupra pagubelor cauzate de o defectare a aparatului.

SERVICE APRÈS VENTE - AFTER SALE SERVICE

FARGROUP EUROPE - 192, Avenue Yves Farge - 37700 St. Pierre-des-Corps - FRANCE

fargroup@fargroup.net

GARANTIE - WARRANTY



RU. ГАРАНТИЯ

Данное изделие обладает имеющей силу контракта гарантией, покрывающей все возможные дефекты изготовления и материала. Гарантия вступает в силу с даты продажи изделия пользователю, для этого достаточно сохранить и предъявить полученный в кассе чек. Гарантия обязывает изготовителя заменить дефектные части изделия. В случае не соответствующего нормам использования изделия, несанкционированного демонтажа или ремонта или небрежного обращения действительная гарантия прекращается. Гарантия не покрывает ущерб, возникший в результате сбоев в работе изделия.

TU. GARANTI

Bu araç, satış tarihinden itibaren, kullanıcının sadece vezne alıncısına sunmasıyla tüm üretim ve malzeme hatasına karşı garantilidir. Garanti eksik olan kısımları değiştirir ve çinir. Bu garanti aracın şartlarına uygun olmayan işleme durumunda, izin verilmeyen kullanımlardan kaynaklanan hasarlarda veya alıcının isteği durumunda uygulanmaz. Garanti malzemenin bir eksikliğinden meydana gelen bir zararda uygulanmaz.

CS. ZÁRUKA

Pro tento nástroj platí smluvní záruka na všechny výrobní a materiálové vady od data prodeje uživateli a na základě předložení pokladního bloku. Záruka spočívá ve výměně vadných částí. Tato záruka neplatí v případě použití přístroje, které neodpovídá normám, ani v případě škod způsobených nepovolenými zásahy nebo nedbalostí ze strany kupujícího. Záruka se nevztahuje na škody způsobené závadou nástroje.

SK. ZÁRUKA

Pre tento nástroj platí zmluvná záruka na všetky výrobné a materiálové chyby od dátumu predaja užívateľovi a na základe predloženia pokladničného bloku. Záruka spočíva vo výmene chybných častí. Táto záruka neplatí v prípade použitia prístroja, ktoré nezodpovedá normám, ani v prípade škôd spôsobených nepovolenými zásahmi alebo nedbalosťou zo strany kupujúceho. Záruka sa nevzťahuje na škody spôsobené poruchou nástroja.

HE. אחריות

עם הצגת חשבונית קופה. האחריות-משמעה לקוי בייצור או בחומר, תחל מיום המכירה למשתמש תחלה הי עכבלי זה חלה אחריות לפי חוזה מפי כל לתקנים ובמקרה של נזק שנגרם על ידי התערבות אינה חלה במקרה של שימוש במשיר שאינו מומחה

די תקלה בכל. החלף תחלקם הקויים אחריות על מאת הקונה. האחריות אינה חלה על נזק שנגרם על מכות או על ידי רשלנות

AR. الضمان

وبناء على مجرد تقديم ببطاقة الشراء. يتلحق اعتباراً من تاريخ البيع إلى المشتري عمل تأقدياً من أي عيب في التصني عوفى الجواد. في حالة تعرضه لآثار أضرار إن هذه الأداة مضمونة حالة الاستخدام غير المطابق لمعايير الجاهز، ولا العاطلة لآي يكون هذا الضمان قابلاً للتطبيق في الذات عن خلل الضمان فإي سبدال الأجزاء قبل التصدي لآي ينطبق الضمان على الضرر عمليات تدخل غير مخصصة أو في حالة الإمداد من ناطقة عن

HU. GARANCIA

Erre a szerszámra szerződéses garanciát vállalunk bármilyen gyártási és anyaghiba felmerülése esetére, a fogyasztó részére történt eladás napjától számítva, a pénztári blokk egyszerű felmutatása ellenében. A garancia a hibás alkatrészek cseréjére terjed ki. Ez a garancia nem érvényes, ha a készüléket nem rendeltetésszerűen használták, sem illetéktelen beavatkozások, vagy a vásárló hanyagsága okozta károk esetén. A garancia nem fedezi azokat a károkat, melyeket a szerszám hibás működése okozott.

SL. GARANCIJA

To orodje je z garancijsko pogodbo zaščiteno proti vsem napakam v izdelavi in v sestavnem materialu od datuma prodaje naprej in ta velja ob predložitvi blagajniškega računa. Garancija velja za zamenjavo delov z napako. Ta garancija ne velja za uporabo orodja, ki ni v skladu z normami, predpisanimi za omenjeno orodje in za primere okvar, ki nastanejo zaradi nedovoljenih posegov na orodju ali zaradi malomarnega rokovanja kupca. Garancija ne velja za škodo, ki jo lahko povzroči okvara orodja.

ET. GARANTII

See tööriist kuulub lepingu järgi garantiiremonti arvestades alates müümise päevast ja kassatseki alusel kasutajale kõigi konstruktsiooni- ja materjalvigade puhul. Garantii seisneb defektsete osade väljavahetamisest. See garantii ei kehti aparadi normide ebatavalise eiramise puhul ega ostja poolt keelatud viisil kasutamisest või hooletussejätmisest tulenevate kahjude korral. Garantii ei kehti seadme defektidest põhjustatud kahjude puhul.

LV. GARANTIJA

Šis prietaisys yra užtikrinamas kaip itin geros kokybės, nuo jo pardavimo datos iki jo panaudojimo, ir jam yra suteikiama garantinis talonas. Garantijos metu galima pakeisti atsiradusius trumplalaikius gedimus. Ši garantija netaikoma esant netinkamam naudojimui ar nesilaikant reikiam šio aparato vartojimo instrukcijų, tai pat pačiam pirkėjui jį sugadinus. Garantiya taip pat netaikoma, prietaisą naudojant ne pagal paskirtį ir jį apgadinus.

LT. GARANTIJA

Šim darbarikam ir ligumā noteikta garantija

visiem defektiem, kas saistās ar konstrukciju un materiālu, sākot ar pārdošanas datumu, kad mašīnu pārdo lietotājam vienkārtši uzrādāt kases čeku. Garantija iekļauj bojāto daļu nomaiņu. Šī garantija nav derīga, ja aparāts nav lietots saskaņā ar drošības noteikumiem, ne gadījumos ja bojājumi radušies nesankcionētas iekļaušanas gadījumā vai arī pierceja nolaidības dēļ. Garantija nav derīga, ja bojājumi radušies darbarīka defekta dēļ.

HR. JAMSTVO

Ovaj alat ima ugovorno jamstvo u slučaju bilo kakvih nedostataka u konstrukciji i materijalu, od datuma prodaje korisniku uz jednostavno predocenje računa. Jamstvo se sastoji u zamjeni neispravnih dijelova. Ovo se jamstvo ne primjenjuje u slučaju uporabe i eksploatacije koja nije sukladna standardima uredaja, niti u slučaju štete uzrokovane neovlaštenim intervencijama ili nemarom kupca.

Jamstvo se ne primjenjuje na štetu uzrokovanu nekim nedostatkom alata.

SERVICE APRÈS VENTE - AFTER SALE SERVICE

FARGROUP EUROPE - 192, Avenue Yves Farge - 37700 St. Pierre-des-Corps - FRANCE

fargroup@fargroup.net





FAR GROUP EUROPE

Une société du groupe **SIGMA**

192, Avenue Yves Farge
37700 St. Pierre-des-Corps
FRANCE

fartools.com

