

FAR TOOLS



MM 2315
Professional Machine

© FAR GROUP EUROPE

113371-E-20110117



FR	<i>Combiné Ponceur</i>
EN	<i>Belt and disc sander</i>
DE	<i>Combischleifer</i>
ES	<i>Lijadora Combinada</i>
IT	<i>Levigatrice combinata</i>
PT	<i>Lixasdeira</i>
NL	<i>Bandschuurachine</i>
EL	Σύνθετη μηχανή λείανσης
PL	<i>Bandschuurachine met schuurschijf</i>
FI	<i>Lautas/nauhahiomakone</i>
SV	<i>Bandslipmaskin med sliptallrik</i>
BU	Комбинирана шлифовъчна машина
DA	<i>Kombineret pudsemaskine</i>
RO	<i>Mașină de șlefuit combinată cu polizor</i>
RU	Комбинированный шлифовальный станок
TU	<i>Kombineli parlatma makinesi</i>
CS	<i>Brusný robot</i>
SK	<i>Kombinovaná brúska</i>
HE	טרממ בלושמ.
AR	لقص ةعومحم
HU	<i>Kombinált csiszoló</i>
SL	<i>Žaga rezljača</i>
ET	<i>Kombineeritud lihviija</i>
LV	<i>Kombinuota (mišri) grēzimo mašina</i>
LT	<i>Kombinētā šļīpmašina</i>

www.fartools.com

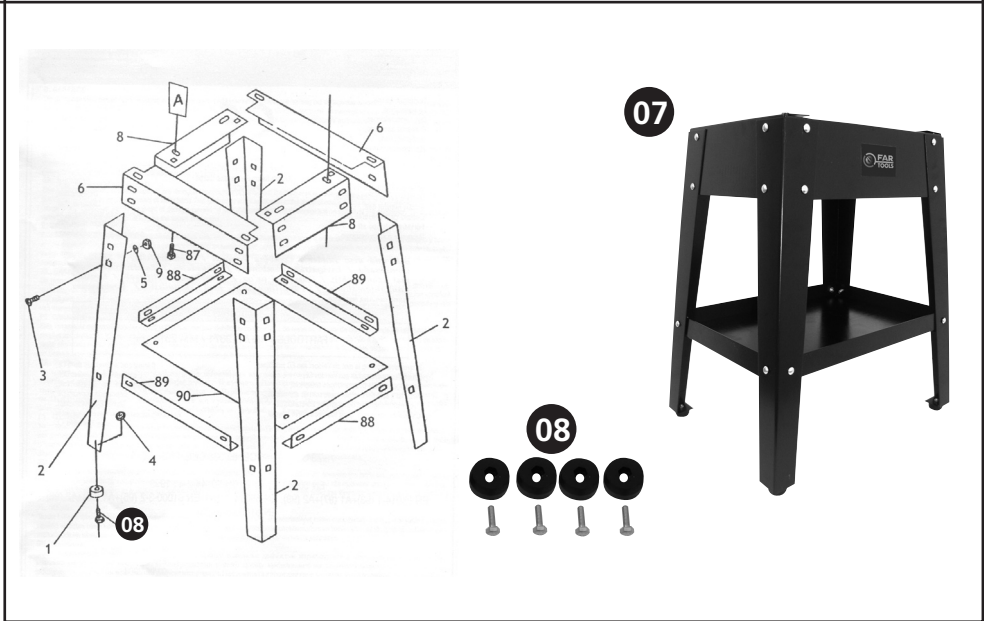
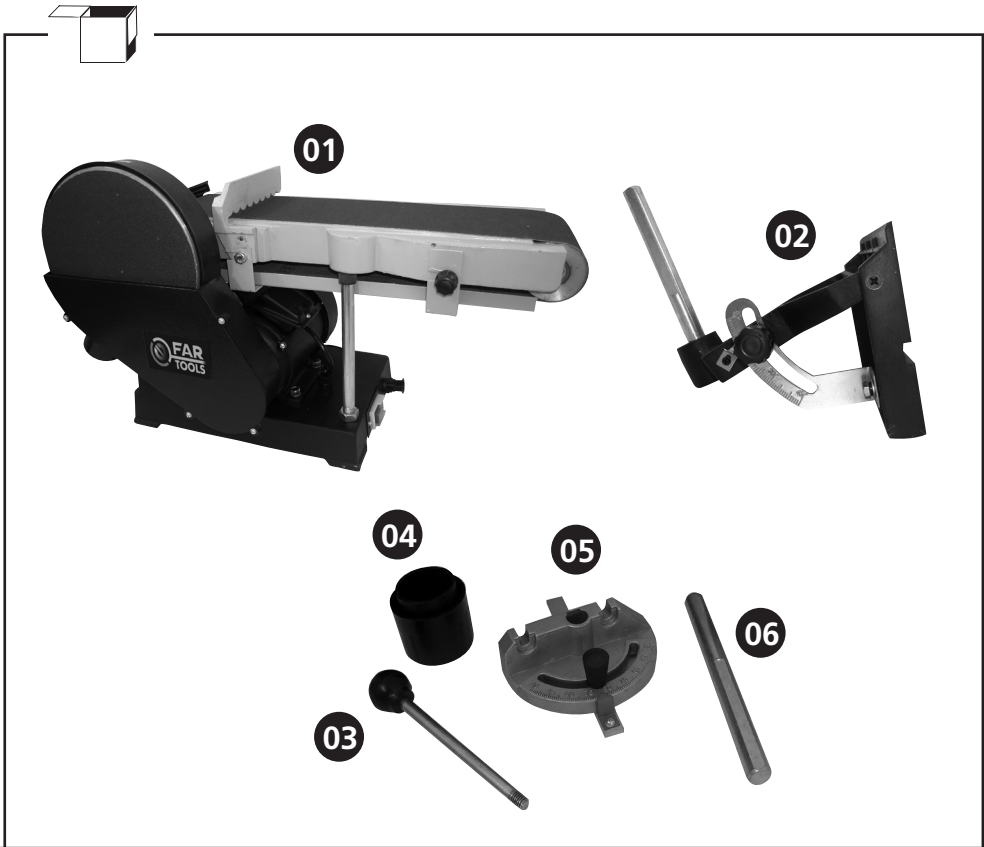

© FAR GROUP EUROPE





2 

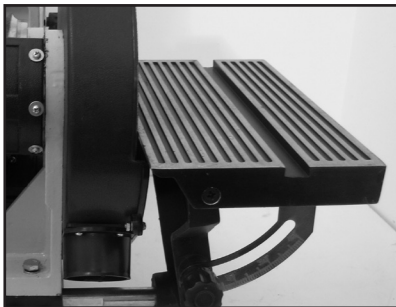
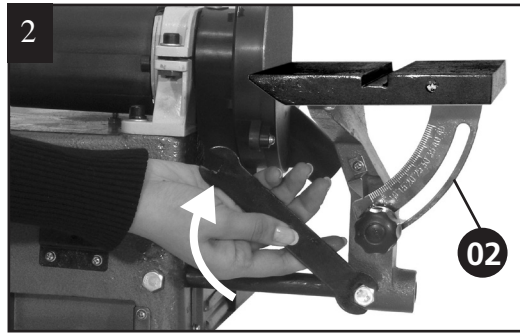
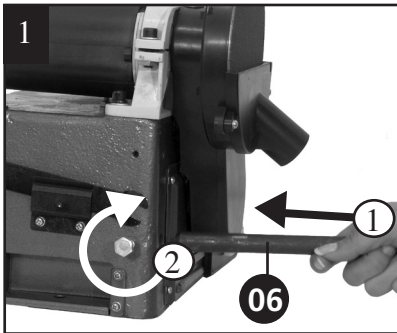
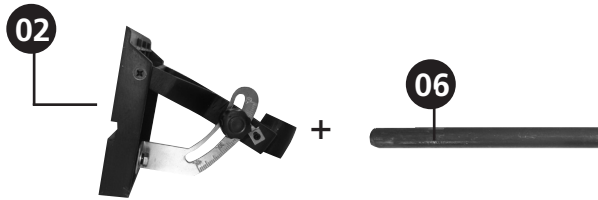

90° 

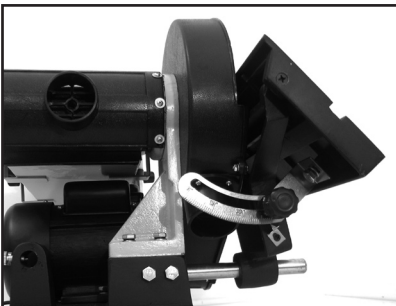

45° 





3

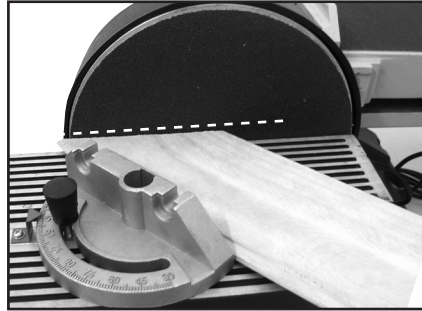
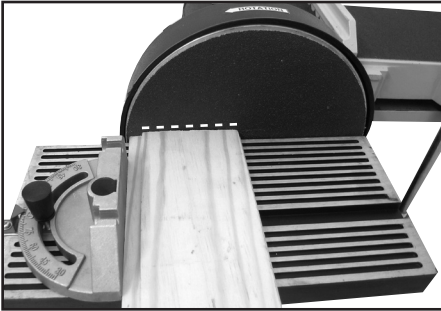
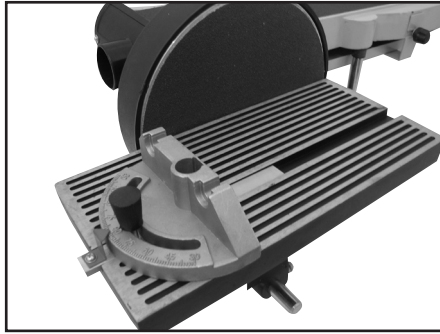

90°

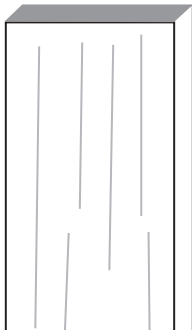

45°

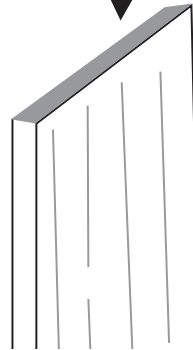



4

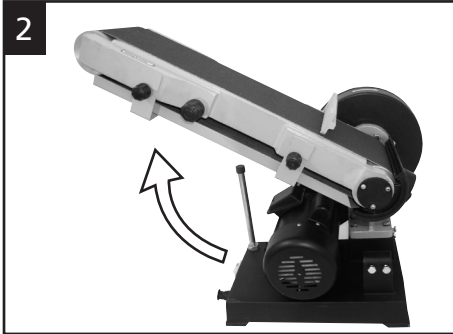

5

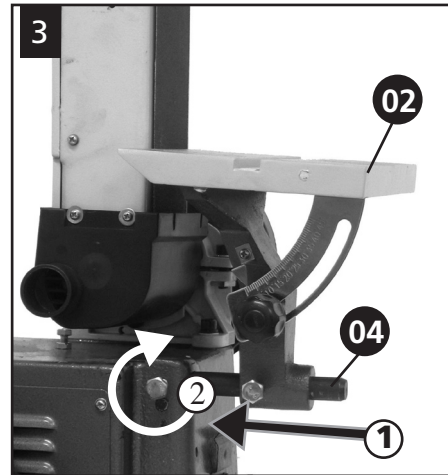
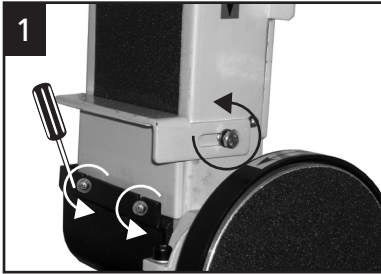

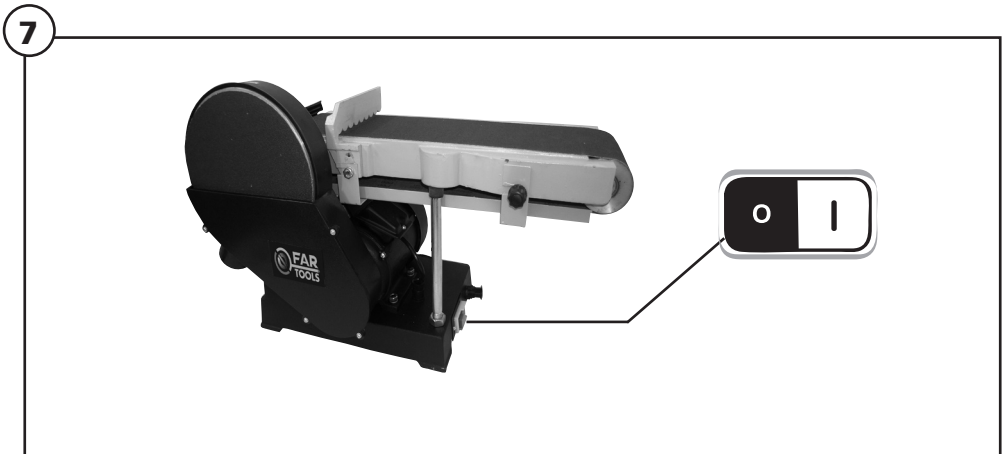
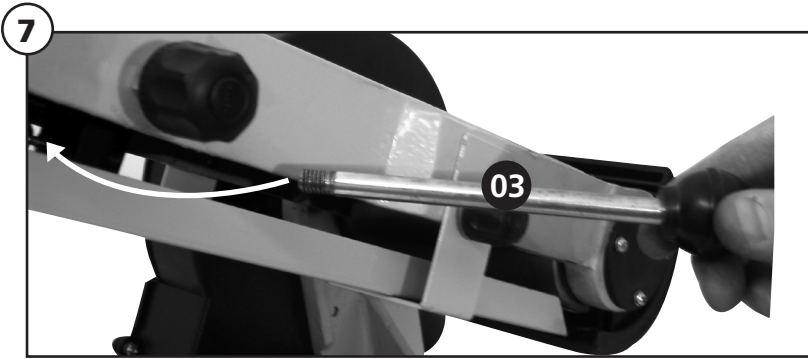
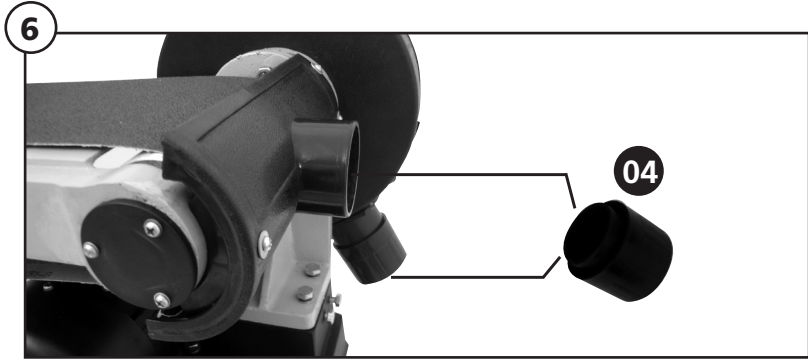



9

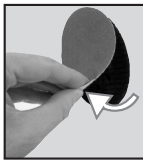
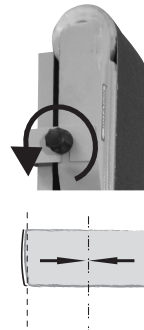
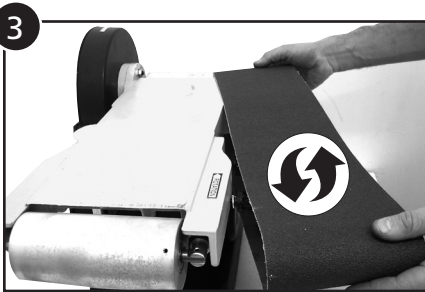
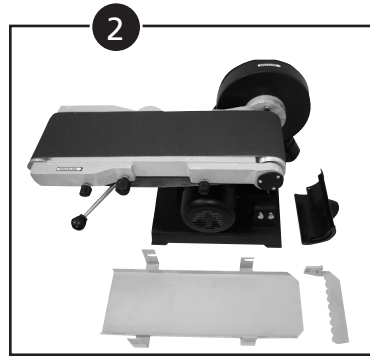
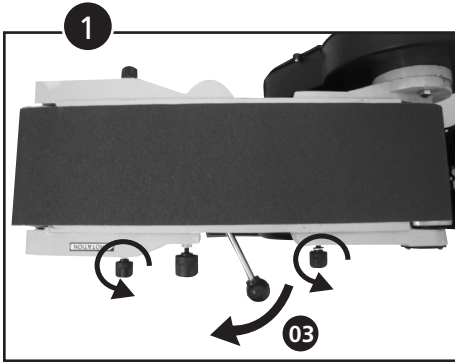

113858



230 mm



A 40 x 2
A 80 x 2
A 120 x 2

113860
113862
113864



150 x 1220





A 120 x 1
A 80 x 1
A 40 x 1

© FAR GROUP EUROPE





	<p>Tension et fréquence assignée: Nominal frequency and power: Spannung und Frequenz: Tensión y frecuencia fijada: Tensione e frequenza assegnata: Tensão e frequência fixa: Aangewezen spanning en frequentie: Ονομαστική τάση και συχνότητα: Napięcie i częstotliwość przydzielona: Jännite ja määrätty taajuus: Angiven spänning och frekvens: Anført spænding og frekvens: Tensiune și frecvență de lucru:</p>	<p>Заданное напряжение и частота: Tahsis gerilimi ve frekans: Stanovené napětí a frekvence: Stanovené napätie a frekvencia: מחצת ותדר מוקצב. الغالبية والذبذبة المبرمجة. Névleges feszültség és frekvencia: Napetost in določena frekvenca: Консумирано напрежение и честота : Määratud pinge ja sagedus Nustatytą jłtampa ir dažnis Noteiktais spriegums un frekvence.</p>	230 V ~ 50 Hz
---	--	---	----------------------

	<p>Puissance assignée: Nominal power: Leerlaufdrehzahl: Potencia fijada: Potenza assegnata: Potência assinada: Onbelast toerental: Ονομαστική η ισχύς : Prędkość na biegu jałowym: Teho: Angiven effekt: Anført styrke: Putere de lucru:</p>	<p>Заданная мощность: Tahsis edilen güç: Stanovený příkon: Predpísaný výkon: כוח מוקצב. القدرة المبرمجة. Névleges teljesítmény : Določena jakost: Консумирана мощност: Määratud võimsus. Nustatytą galia Noteiktā jauda</p>	750 W
---	--	---	--------------

	<p>Vitesse à vide: No-load speed: Drehzahl unbelastet: Velocidad vacía: Velocità a vuoto: Velocidade no vácuo: Leerlaufdrehzahl: Ταχύτητα στο κενό: Prędkość bez obciążenia: Tyhjäkäyntinopeus Tomgångshastighet: Hastighed i ubelastet tilstand: Viteza în gol:</p>	<p>Скорость вращения на холостом ходу: Boşalma hızı: Rychlost naprázdno: Rýchlost' pri chode naprázdno: מהירות ריק. السرعة على الفارغ. Üres sebesség: Prosti tek: Скорост на празни обороти: Kiirus tühikäigul Tuščio prietaiso greitis Tukšgaitas ātrums</p>	1400 min⁻¹
---	--	---	------------------------------

	<p>Soumis à recyclage Subjected to recycling Sujeto a reciclaje Sottoposti a riciclaggio Sujeitos à reciclagem Não deite no lixo : Niet wegwerpen : Μην την πετάτε : Nie wyrzucac : Älä heitää pois luontoon : Batteriet får inte kastas : Bortkast det ikke: Nu le auncati :</p>	<p>Не выбрасывайте в мусорный ящик Atmayiniz : Nevyhazujte je do bežného odpadu : Neodhadzovat : אין לזרוק סוללות فلا ترمدها هكذا في القمامة. ne mečíte! Ne odvržite ga/jih vstran : Не го изхвърляйте : Ärge visake seda minema : Nemétykíte : Nemest :</p>	X
---	---	---	----------

	<p>Classe d'isolement : 1 Insulation class : 1 Isolierung klasse : 1 Aislamiento clase : 1 Isolamento classe : 1 Isolamento classe : 1 Isolatie Klasse : 1 Εργαλειο τάξη : 1 Izolacja Klasy : 1 Eristysluokka : 1 Isolering Klass : 1 Isoleringsklasse 1 Clasă izolatie : 1</p>	<p>Клас изолации 1 : Yalıtım derecesi : 1 Třída izolace : 1 Izolačný systém 1 סוג בידוד 1. فئة العزل 1. Szigetelési osztály : 1 Razred izolacije : 1 Инструмент Клас : 1 Isolatsiooniklass 1 Izolācijas rūšis 1 Izolācijas klase 1</p>	X
--	---	---	----------







	<p>Conformité européenne Conforms to EC standards : CE-Konformität : Cumples con las directivas CE : Conforme alle norme CE : Conforme às normas CE : Voldoet aan de EG-normen : Συμφώνω με τα πρότυπα Zgodność z normami CE : EU-standardien mukainen : EU-standardien mukainen : Overholder EU standarderne : Conform cu normele europene:</p>	<p>соответствие европейским стандартам: Avrupa uygunluk : evropská shoda : európska dohoda : התאמה לתקנים האירופיים مطابق للمواصفات الأوروبية evropska ustreznost : európai megfeleléség : Съответствие с европейските норми : Euroopa Liidu vastavusmärk Europinių normų atitikima Atbilstība Eiropas standartiem</p>	X
	<p>Lire les instructions avant usage : Read the instructions before use : Vor Einsatz des Geräts Anweisung lesen : Léase las instrucciones antes de usar : Leggere le istruzioni prima dell'uso : Ler as instruções antes da utilização : Lees voor het gebruik de instructies : Διαβάστε τις οδηγίες χρήσης : Zapoznać się instrukcją przed użyciem : Lue ohjeet ennen käyttöä : Läs anvisningarna före användning : læs instruktionerne før brug Înainte de utilizare, cititi instructiunile :</p>	<p>Внимательно прочитайте следующие инструкции : Kullanmadan talimatları okuyunuz : Pozorně si přečtěte následující pokyny : Pred použitím si prečítajte pokyny : דרום חילוני اقرأ التعليمات قبل الاستخدام használat előtt olvassuk el az utasítást : Pred uporabo preberite ustrezna navodila : Прочетете указанията за употреба : Enne kasutamist lugege instruksiooni Prieš naudojimą perskaityti instrukciją izlasīt instrukcijas pirms lietošanas</p>	X
	<p>Danger : Danger : Gefahr : Peligro : Pericolo : Perigo : Gevaar : Κινδύνοζ : Niebezpieczeństwo : Vaara : Fara : Fare : Pericol :</p>	<p>Опасно : Tehlike : Nebezpečí : Nebezpečenstvo : סכנה. خطر. Veszély : Nevarnost: Опасно : Oht Pavojus Bīstamība</p>	X
		X	
	<p>Poids : Weight : Gewicht : Peso : Peso : Peso : Gewicht : Βάρος : Masa : Paino : Vikt : Vægt : Greutate :</p>	<p>Вес : Ağrlık : Hmotnost : Hmotnost' : משקל الوزن. Súly : Teža : Терло : Raskus Svoris Svars</p>	38.70 kg





	<p>Porter des lunettes de sécurité : Wear protective eyewear : Schutzbrille tragen : Llevar puestas gafas protectoras : Portare de gli occhiali di sicurezza : Utilizar óculos de segurança : Draag een veiligheidsbril : Φορέστε Προστατευτικά γυαλιά : Zakładać okulary ochronne : Käytä suojalaseja : Använd skyddsglasögon : Der skal benyttes sikkerhedsbriller : Purtati ochelari de protecție :</p>	<p>Наденьте защитные очки : Güvenlik gözlükleri takın : Požívajte bezpečnostní brýle : Noste ochranné okuliare : תוהיטב ביכרהל מן חמל נזארות וקאי. Viseljen védőszemüveget : Nositi zaščitna očala : Да се използва защитни очила : Kandke kaitseprille Nešioti apsauginius akinius Valkāt aizsargbrilles</p>	X
---	--	---	---

	<p>Porter un masque anti-poussière: Wear a dust mask : Staubschutzmaske tragen : Llevar puesta una careta de protección contra el polvo : Indossare una mascherina anti-polvere : Utilizar uma máscara anti-poeira : Draag een stofmasker : χρήση προστατευτική μάσκα : Zakładać maskę przeciwpyłową Käytä pölysuojust : Bär mask mot damm : Der skal benyttes beskyttelsesmaske mod støv: Purtati mască anti-praf :</p>	<p>Наденьте респиратор : Toza karşı maske takın : Používajte masku proti prachu : Noste ochrannú masku proti prachu : קבא דגן הכסמ שובחל מן ליס קזאע מזאז ללגבאר. Viseljen porvédő maszkot Nositi zaščitno masko proti prahu: Да се използва защитна маска : Kandke tolmumaski. Dėvėti respiratorių Valkāt aizsarg masku pret putekļiem</p>	X
---	--	---	---

	<p>Porter une protection auditive: Wear hearing protective equipment: Gehörschutz tragen: Llevar puesta una protección auditiva: Portare una protezione uditiva: Utilizar uma protecção auditiva: Draag gehoorbeschermers: Φορέστε Προστατευτικά ακουστικά Zakładać słuchawki ochronne Käytä kuulosuojaimia: Bär hörselskydd: Der skal benyttes høreværn: Purtati căști de protecție auz:</p>	<p>наденьте средства звуковой защиты: İşitsel koruma aleti takın: Používajte ochranu sluchu: Noste ochranné slúchadlá: יש ל הרכיב הגנת שמיעה ליס חזנה זרז ללזחגיח. Viseljen fülvédőt Nositi zašito ušes: Да се използва слухови защитни средства: Kandke kõrvakaitset Nešioti apsaugą nuo triukšmo valkāt dzirdes aizsarglīdzekli</p>	X
--	---	---	---

	<p>Porter des gants : Use rubber gloves : Schutzhandschuhe tragen : Llevar guantes de protección : Indossare i guanti di protezione : Utilizar luvas de protecção : Draag veiligheidshandschoenen : χρήση προστατευτικών γαντιών : Używać rękawic ochronnych : Käytä suojakäsineitä : Använd skyddshandskar : Der skal benyttes handsker : Purtati mánusi :</p>	<p>Наденьте перчатки : Eldiven takın : Noste rukavice : Noste rukavice : תופכ שובלל מן ליס קזאזאז. Viseljen kesztyű t Nositi rokavice: а се използва предпазни ръкавици : Kandke kindaid Mūvēti pirštines Valkāt cimduš</p>	X
---	---	---	---





		ø 230 mm
		336 m/s
		150 x 1220 mm
		0 -> 45°
		310 x 160 mm

Niveau de pression acoustique : Acoustic pressure level : Schalldruckpegel : Nivel de presión acústica : Livello di pressione acustica : Nível de pressão acústica : Niveau akoestische druk : Σπίθμη Θορύβου : Poziom mocy akustycznej : Käytä kuulosuojaimia : Ljudtrycksnivå : Lydtryk : Nível presiune acustică :	Уровень акустического давления. : Akustik basınç seviyesi : Hladina akustického tlaku : Hladina akustického tlaku : רמת לחץ אקוסטי. مستوى الضغط السمعي. A hangnyomás szintje : Nivo akustičnega pritiska: Равнище на акустично налягане : Helirõhu nivoo Akustinio spaudimo lygis Akustiskā spiediena līmenis	80 dB (A)
---	--	------------------

MM 2315 / 750 W:

NIVEAU SONORE D'EMISSION:

A VIDE

Pression acoustique LpA poste opérateur
Incertitude

80 dB
3

Valeurs déterminées suivant le code d'essai de l'annexe B de la norme EN 61029-1 avec emploi des normes de base ISO 11201 et ISO 3744.

Les niveaux de pression acoustique obtenus in situ dépendent:

- Des niveaux réels de la machine considérées, en prenant en compte les incertitudes déclarées;
- Du local et de l'installation de la machine. Préférez une pièce dont l'acoustique est plus feutrée. Evitez les pièces vide à grande résonance. Placez vous auprès d'une fenêtre le cas échéant.
- Des outils montés, des pièces travaillées, des réglages choisis,...





MM 2315

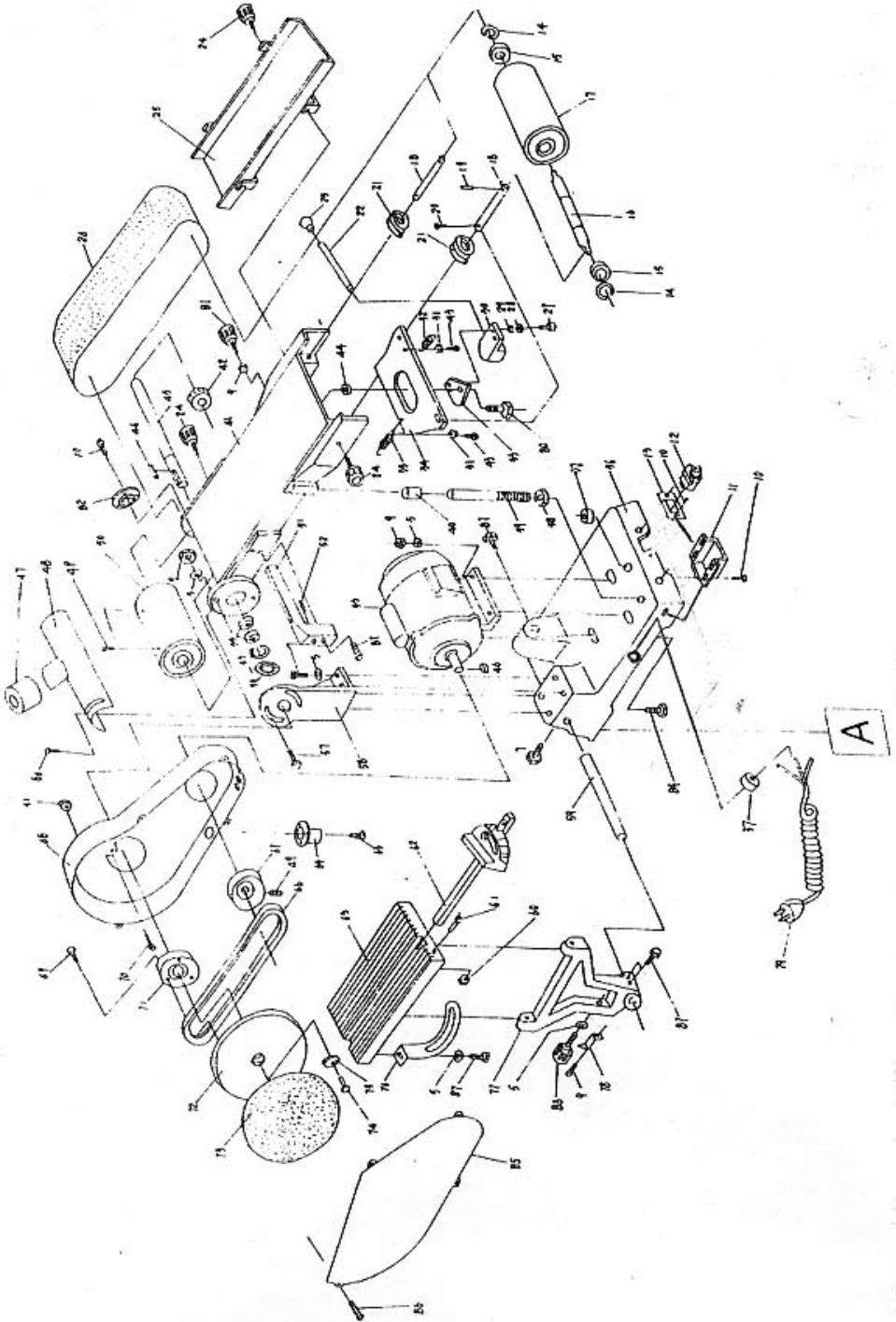

© FAR GROUP EUROPE





VERKLARING VAN OVEREENSTEMMING
DECLARATION DE CONFORMITE
KONFORMITÄSERKLÄRUNG
DECLARAÇÃO DE CONFORMIDADE
OM ÖVERENSSTÄMMELSE
Överensstemmelseerklæring

Declarație de conformitate
 Декларация соответствия
 UYGUNLUK BEYANI
 Prohlášení shody
 Декларация за съответствие с нормите

DECLARACION DE CONFORMIDAD
DICHIAZIONE DI CONFORMITA
DECLARATION CONFORMITY
DECLARACIA ZGODNOSCI Z NORMAMI
VAATIMUSTENMUKAISUUSVAKUUTUS
Δήλωση συμμόρφωσης/συμμόρφωσης
Vyhlasenie zhody
הצהרת תואמת
التصريح بالمطابقة
Egyezőségi nyilatkozat
Izjava o skladnosti

Ondergetekende,
 Le soussigné,
 Der Unterzeichner,
 O abaixo assinado,
 Undertecknad,
 Долуподписаният
 Undertegnede
 Subsemnatul,
 Я, нижеподписавшийся,
 Ímzalayan,
 Níže podepsaný,

El suscrito,
 Il sottoscritto,
 The undersigned,
 Nínej podpísany
 Allekirjoittanut,
 Ουπτογεγραμμένος/
 Nižšie podpísaný
 המחתום הנני
 الجوقع أدناه
 Alulírott,
 Podpisani,

Verklaart hiermede dat,
 Déclare par la présente que,
 Erklärt hiermit daß,
 Declara pela presente que,
 Förklarar härmed att
 Заявлява с настоящото
 erklærer hermed, at
 Declar prin prezenta că,
 настоящим подтверждаю, что
 Mevcut belgeyle beyan ediliyor ki,
 tímto prohlašuje, že,



FAR GROUP EUROPE
 206, rue Marcel CACHIN
 37700 Saint-Pierre-des-Corps
 FRANCE

Declara por la presente, que,
 Dichiare che,
 Declares that,
 OÖwiadcza niniejszym, że
 Ilmoitetaan täten että,
 Δηλώνει με την Παρούσα
 týmto vyhlasuje, že
 מצהיר בזה כי
 یصريح إستنادا إلى ذلك
 kijelentem, hogy a készülék Izjavlja da,

Belt and disc sander / Combiné Ponceur / Combischleifer / Lijadora Combinada / Levigatrice combinata / Lixasdeira / Bandschuurachine / Ζώνθητη μηχανή
 Λείανσης / Bandschuurachine met schuurshijf / Lautas/nauhahiomakone / Bandslipmaskin med sliptallrik / Комбинирана шлифовъчна машина / Kombineret
 pudsemaskine / Maşină de şlefuit combinată cu polizor / Комбинированный шлифовальный станок / Kombiniert parlatma makinesi / Brusný robot /
 Kombinovaná brúška / מרטמ בלוימ / لقص ذو مجم / Kombinált csiszoló / Zaga rezljača. / Kombineeritud lihvija / Kombinuota (mišri) grężimo mašina / Kombinētā
 slīpmašīna

code

FARTOOLS / 113371 / MM 2315 / MM4123

In overeenstemming is met en Voldoet aan EG richtlijnen,
 Est conforme et satisfait aux normes CE,
 Den folgenden EU-Bestimmungen entspricht,
 Respeita e está em conformidade com as normas CE,
 Överensstämmer med och uppfyller EG-standarder,
 Съответства и отговаря европейските норми
 er i overensstemmelse med og overholder EU standarderne
 Este conform și satisface normele CE
полностью соответствует и удовлетворяет
требованиям стандартов ЕС
 CE şartlara uygundur,
 odpovídá normám ES.

Cumple con la directivas de la CE,
 E conforme alle direttive CEE,
 Complies with the EEC standards,
 Odpowiada normom UE,
 Täyttää EU-vaatimukset,
 Είναι σύμμορφων και ανταποκρίνεται στα Πρότυπα CE
 zodpovedá normám ES.
 מתאים ועונה לתקני CE
 بأن الـجـهان يطابق و يلبى معايير مجموعة الدول الأوروبية
 kielégíti a CE szabványok előírásait.
 Je v skladu z in izpolnjuje norme Evropske skupnosti.

2006/42/EC, 2006/95/EC, 2004/108/EC

EN61029-1:2000 EN55014-1/A2:2002
 EN55014-2/A1:2001 EN61000-3-2:2000
 EN61000-3-3/A1:200

Christophe HUREL,
 Président Directeur Général
 23/06/2010

© FAR GROUP EUROPE





FR. GARANTIE

Cet outil est garanti contractuellement contre tout vice de construction et de matière, à compter de la date de vente à l'utilisateur et sur simple présentation du ticket de caisse. La garantie consiste à remplacer les parties défectueuses. Cette garantie n'est pas applicable en cas d'exploitation non conforme aux normes de l'appareil, ni en cas de dommages causés par des interventions non autorisées ou par négligence de la part de l'acheteur. La garantie ne s'applique pas sur les dommages causés par une défaillance de l'outil.

DE. GARANTIE

Die Garantiezeit für dieses Gerät in bezug auf Konstruktions- und Materialfehler beträgt lt. Vertrag bei Vorlage des Kassensbons. Die Garantieleistung besteht im Ersatz schadhafter Teile. Die Garantie erlischt bei einem Einsatz des Geräts, der nicht normentsprechend ist, bei Schäden, die auf unsachgemäße Eingriffe zurückzuführen sind bzw. bei Nachlässigkeit seitens des Käufers. Die Garantie erstreckt sich nicht auf Schäden, die auf Fehlfunktionen des Geräts zurückzuführen sind.

IT. GARANZIA

Quest' attrezzo è garantito per contratto contro qualsiasi difetto di costruzione e di materia, a partire dalla data di vendita all' utente e su semplice presentazione dello scontrino. La garanzia consiste nel sostituire le parti difettose. Questa garanzia non è applicabile in caso di sfruttamento non conforme alle norme dell' apparecchio, né in caso di danni causati da interventi non autorizzati o da negligenza da parte dell' acquirente. La garanzia non si applica ai danni causati da un'avarìa dell'attrezzo.

EN. GARANTEE

This tool is guaranteed, in writing, against any defect in manufacture or parts from the date of sale, upon simple presentation of the sales slip. The guarantee is limited to the replacement of faulty parts. This guarantee is not applicable in the event of usage which is not conform with the intended usage of the apparatus, nor in the event of damage caused by unauthorised servicing or negligence on behalf of the purchaser. This guarantee does not apply to any damage caused by the failure of this tool.

ES. GARANTIA

Esta herramienta se garantiza contractualmente contra todo defecto de construcción y materia, a partir de la fecha de venta a l' usuario y sobre simple presentación del recibo de caja. La garantía consiste en sustituir a las partes defectuosas. Esta garantía no es aplicable en caso de explotación no conforme a las normas del aparato, ni en caso de daños causados por intervenciones no autorizadas o por negligencia por parte del comprador. La garantía no se aplica sobre los daños causados por un fallo del herramienta.

NL. GARANTIE

Dit gereedschap heeft een garantie tegen constructiefouten en materiaaldefecten, die geldig is vanaf de aankoopdatum door de gebruiker, op vertoning van de kassabon. De garantie betreft de vervanging van de defecte onderdelen. Deze garantie is niet van toepassing indien het apparaat niet volgens de normen gebruikt is, noch in geval van schade veroorzaakt door oneigenlijk gebruik of nalatigheid van de koper. De garantie is niet van toepassing op schade voortvriend uit een defect van het gereedschap.

PT. GARANTIA

Esta ferramenta tem uma garantia contratual contra qualquer defeito de construção e de material, a partir da data de venda ao utilizador e sobre simples apresentação do talão da caixa. A garantia consiste em substituir as partes defeituosas. Esta garantia não é aplicável no caso de exploração não conforme às normas do aparelho, nem em caso de danos causados pelas intervenções não autorizadas ou por negligência da parte do comprador. A garantia não se aplica para os danos causados por uma falha da ferramenta.

EL. Εγγύηση

Το εργαλείο αυτό φέρει συμβατική εγγύηση για οποιοδήποτε ελάττωμα κατασκευής απ'ο την ημερομηνία Πώλησης στο χρήστη. με απλή Προσκόμιση της απ'ο'οειξηζ αγοράς. Η εγγύηση αποτελείται απ'ο την αντικατάσταση των ελαττωματικών τμημάτων. Η Παρο'υσα εγγύηση οεν εφαρμ'οζεται σε Περίπτωση χρήσης μη σύμφωνα με τα Πρότυπα της συσκευής, η σε Περίπτωση ζημιάς που Προκλήθηκε απ'ο μη ευκεκρυμ'ειρη εΠ'εμβαση ή απ'ο αμ'ελεια του αγοραστή. Η εγγύηση οεν εφαρμ'οζεται στις ζημίες που Προκαλούνται απ'ο βλάβη του εργαλείου Σταυρο'ι κενού Διασθημο-Παρέμβυσμα

PL. GWARANCJA

Narz dzie jest obj'ęte gwarancją na wszelkie wady konstrukcyjne i materia[łowe, licząc od daty sprzed'any u'ytkownikowi i po okazaniu paragonu kasowego. Gwarancją obejmuje wymian' cz'łci wybrakowanych. Gwarancją nie znajduje zastosowania w przypadku u'ytkowania niezgodnego z normami urz'adzenia, ani w przypadku szkód spowodowanych dzia[łaniami niedozwolonymi lub zaniebdaniami ze strony nabywcy. Gwarancją nie obejmuje szkód powsta[lych z powodu upadku urz'adzenia.

SV. GARANTI

Detta verktyg har en avtalsenlig garanti mot konstruktions- och materialfel, från och med tidpunkten för användarens inköp och genom uppvisning av kasskvittot. Garantin består i att ersätta de bristfälliga delarna. Denna garanti gäller inte om användningen inte motsvarar apparatens standarder, inte heller vid skador som orsakas av ej tillåtna ingrepp eller på grund av köparens vårdslöshet. Garantin gäller inte för skador som orsakats av att verktyget fungerat bristfälligt.

FI. TAKUU

Tämän laitteen takuu on voimassa sopimuksenmukaisesti kattaen kaikki rakenne- ja materiaaliiviat lukien ostopäivästä kassakuittia vastaan. Takuu sisältää viallisten osien korvaamisen. Takuu ei korvaa ohjeidenvastaista käyttöä eikä valtuuttamattomien henkilöiden käsitteilyä tai ostajan huolimattomuudesta aiheutuneita vahinkoja. Takuu ei vastaa myöskään toimintahäiriöistä aiheutuneita vahinkoja.

BV. Гаранция

Този инструмент е под договорна гаранция срещу всякакъв дефект в изработката и използваните материали, считано от датата на продажба на потребителя и само срещу представяне на касовата бележка. Гаранционното обслужване се състои в замяна на дефектните части. Настоящата гаранция не е валидна когато апаратът се използва по начин, несъответстващ на стандарта за работа с него, както и в случай на щети, нанесени от неоторизирани лица, или вследствие на проявена небрежност от страна потребителя.

Гаранцията не покрива щети, произтекли вследствие на техническа неизправност на апарата.





DA. GARANTI

Dette værktøj er dækket af en garantikontrakt for konstruktions- og materialefejl, som gælder fra købsdatoen ved visning af kassebonen. Garantien består i at udfiske de defekte dele. Garantien dækker ikke fejl opstået som følge af anvendelse, som ikke overholder standarderne for apparatet, eller skader opstået ved ikke autoriserede indgreb eller sløsethed fra brugerens side. Garantien dækker ikke skader opstået, fordi værktøjet har svigtet.

RO. GARANȚIE

Acest aparat este garantat din punct de vedere contractual împotriva tuturor viciilor de construcție și de material, începând de la data vânzării lui către utilizator și la simpla prezentare a bonului de casă. Garanția constă în înlocuirea componentelor defecte. Această garanție nu se aplică în cazul exploatarei în alt mod decât cel recomandat de normele aparatului și nici în caz de stricăciuni provocate de intervenții neautorizate sau prin neglijența cumpărătorului. Garanția nu se aplică asupra pagbelor cauzate de o defectare a aparatului.

RU. ГАРАНТИЯ

Данное изделие обладает имеющей силу контракта гарантией, покрывающей все возможные дефекты изготовления и материала. Гарантия вступает в силу с даты продажи изделия пользователю, для этого достаточно сохранить и предъявить полученный в кассе чек. Гарантия обязывает изготовителя заменить дефектные части изделия. В случае не соответствующего нормам использования изделия, несанкционированного демонтажа или ремонта или небрежного обращения действие гарантии прекращается. Гарантия не покрывает ущерба, возникшего в результате сбоев в работе изделия.

TU. GARANTI

Bu araç, satış tarihinden itibaren, kullanıcının sadece vezne alınıdını sunmasıyla tüm üretim ve malzeme hatasına karşı garantilidir. Garantii eksik olan kısımları değiştirmek içindir. Bu garantii aracın şartlarına uygun olmayan işleme durumunda, izin verilmeyen kullanımlardan kaynaklanan hasarlarda veya alıcının isteği durumunda uygulanmaz. Garantii malzemenin bir eksikliğinden meydana gelen bir zararda uygulanmaz.

CS. ZÁRUKA

Pro tento nástroj platí smluvní záruka na všechny výrobní a materiálové vady od data prodeje uživateli a na základě předložených pokladničního bloku. Záruka spočívá ve výměně vadných částí. Tato záruka neplatí v případě použití přístroje, které neodpovídá normám, ani v případě škod způsobených nepovolenými zásahy nebo nedbalostí ze strany kupujícího. Záruka se nevztahuje na škody způsobené závadou nástroje.

SK. ZÁRUKA

Pre tento nástroj platí zmluvná záruka na všetky výrobné a materiálové chyby od dátumu predaja užívateľovi a na základe predloženia pokladničného bloku. Záruka spočíva vo výmene chybných častí. Táto záruka neplatí v prípade použitia prístroja, ktoré nezodpovedá normám, ani v prípade škôd spôsobených nepovolenými zásahmi alebo nedbalosťou zo strany kupujúceho. Záruka sa nevzťahuje na škody spôsobené poruchou nástroja.

HE. אחריות

הי עלכלי זה חלה אחריות לפי חוזה מפני כל ליקוי בייצור או בחומר, החל מיום המכירה למשתמש עם הצגת חשבונית קופה. האחריות-משמעה החלף תחלקם הלקויים אחריות זו אינה חלה במקרה של שימוש במכשיר שאינו מתאים לתקנים ובמקרה של נזק שנגרם על ידי התערבות תללל סמכות או על ידי רשלנות מאת הקונה. האחריות אינה חלה על נזק שנגרם על ידי תקלה בכלל.

AR. الضمان

إن هذه الة مضمونة تعاقدياً من أي عيب في التصني عوفي الجواء، إعتباراً من تاريخ البيع إلى المستعمل وبنءاً على مجرد تقديم بطاقة الشراء، يت علق الضمان فأي سبب لال أجزاء الة مضمون هذا الضمان قابل للتطبيق في حالة الإستخدام غير المطابق لمعايير الة، وولا في حالة تعرضه لالتلفات ناتجة عن عمليات تدخل غير مخصصة أو في حالة الإهمال من قبل المشغري الة ينطبق الضمان على المخرجات الناتجة عن علق

HU. GARANCIA

Erre a szerszámra szerződéses garanciát vállalunk bármilyen gyártási és anyaghiba felmerülése esetére, a fogyasztó részére történő eladás napjától számítva, a pénztári blokk egyszerű felmutatása ellenében. A garancia a hibás alkatrészek cseréjére terjed ki. Ez a garancia nem érvényes, ha a készülék nem rendeltetésszerűen használták, sem illetéktelen beavatkozások, vagy a vásárló hanyagsága okozta károk esetén. A garancia nem fedezi azokat a károkat, melyeket a szerszám hibás működése okozott.

SL. GARANCIJA

To orodje je z garancijsko pogodbo zaščiteno proti vsem napakam v izdelavi in v sestavnem materialu od datuma prodaje naprej in ta velja ob predložitvi blagajniškega računa. Garancija velja za zamenjavo delov z napako. Ta garancija ne velja za uporabo orodja, ki ni v skladu z normami, predpisanimi za omenjeno orodje in za primere okvar, ki nastanejo zaradi nedovoljenih posegov na orodju ali zaradi malomarnega rokovanja kupca. Garancija ne velja za škodo, ki jo lahko povzroči okvara orodja.

ET. GARANTII :

See tööriist kuulub lepingu järgi garantiiremonti arvestades alates müümise päevast ja kasatšeki alusel kasutajale kõigi konstruktsiooni- ja materjalivigade puhul. Garantii seisneb defektsete osade väljavahetamises. See garantii ei kehti aparadi normide ebaavalise eiramise puhul ega ostja poolt keelatud viisil kasutamistest või hooletussejätmisest tulenevate kahjude korral. Garantii ei kehti seadme defektidest põhjustatud kahjude puhul

LV. GARANTIJA :

Šis prietaisas yra užtikrinamas kaip itin geros kokybės, nuo jo pardavimo datos iki jo panaudojimo, ir jam yra suteikiamas garantinis talonas. Garantijos metu galima pakeisti atsiradusius trumplataiškus gedimus. Ši garantija netaikoma esant netinkamam naudojimui ar nesilaikant reikiam šio aparato vartojimo instrukcijų, tai pat pačiam pirkejiui jį sugadinus. Garantija taip pat netaikoma, prietaisą naudojant ne pagal paskirtį ir jį apgadinus

LT. GARANTIJA :

Šim darbarikam ir ligumė noteikta garantija visiem defektiem, kas saistās ar konstrukciju un materiālu, sākot ar pārdošanas datumu, kad mašīnu pārdod lietotājam un vienkārsī uzrādāt kases čeku. Garantija iekļauj bojāto daļu nomaiņu. Šī garantija nav derīga, ja aparāts nav lietots saskaņā ar drošības noteikumiem, ne gadījumos ja bojājumi radušies nesankcionētas iejaukšanās gadījumā vai arī pircēja nolaidības dēļ. Garantija nav derīga, ja bojājumi radušies darbarika defekta dēļ

